

PORT OF PORT TOWNSEND PORT TOWNSEND, WASHINGTON

BOAT HAVEN MARINA STORMWATER IMPROVEMENTS PHASE 2

DRAWING INDEX

SHT #	DWG #	SHEET TITLE
GENERAL		
01	G-001	COVER, LOCATION & VICINITY MAPS, AND DRAWING INDEX
02	G-002	GENERAL ABBREVIATIONS
03	G-003	GENERAL NOTES AND LEGEND
04	G-004	GENERAL EQUIPMENT DESIGNATIONS AND PROCESS IDENTIFICATION CODES
05	G-005	GENERAL PROCESS SYMBOLS
06	G-006	OVERALL SITE PLAN, SURVEY CONTROL, AND KEY MAP
07	G-007	STORMWATER CONVEYANCE FLOW DIAGRAM
DEMOLITION		
08	D-303	VAULT 4 DEMOLITION
CIVIL		
09	C-001	CIVIL ABBREVIATIONS AND NOTES
10	C-002	CIVIL LEGEND
11	C-101	EROSION AND SEDIMENT CONTROL PLAN AND NOTES
12	C-102	EROSION AND SEDIMENT CONTROL DETAILS
13	C-201	STORMWATER CONVEYANCE PLAN AND PROFILE - STA 1+00 TO STA 5+00
14	C-202	STORMWATER CONVEYANCE PLAN AND PROFILE - STA 5+00 TO STA 9+50
15	C-203	STORMWATER CONVEYANCE PLAN AND PROFILE - STA 9+50 TO END
16	C-204	STORMWATER CONVEYANCE PLAN AND PROFILE - STA 50+00 TO STA 53+00
17	C-205	STORMWATER CONVEYANCE PLAN AND PROFILE - STA 53+00 TO END
18	C-301	STORMWATER VAULT MODIFICATIONS
19	C-302	SAND FILTER MODIFICATIONS
20	C-303	STORMWATER TREATMENT PLAN
21	C-304	STORMWATER TREATMENT SECTIONS
22	C-305	GRADING PLAN
* 23	C-306	STORMWATER TREATMENT SYSTEM PROFILES
* 24	C-307	CHITOSAN MANIFOLD SECTION
* 25	C-308	STORMWATER TREATMENT CHAMBER PLAN AND SECTION ENLARGEMENT - I
* 26	C-309	STORMWATER TREATMENT CHAMBER PLAN AND SECTION ENLARGEMENT - II
* 27	C-500	BIOFILTRATION TYPICAL DETAILS
28	C-501	CIVIL DETAILS - I
29	C-502	CIVIL DETAILS - II
* 30	C-503	CIVIL DETAILS - III
LANDSCAPING		
* 31	L-001	BIOFILTRATION PLANTING PLAN
* 32	L-002	PLANTING DETAILS AND NOTES
STRUCTURAL		
33	S-001	GENERAL NOTES
34	S-101	STRUCTURAL KEY MAP
35	S-102	STORMWATER TREATMENT FACILITY PLAN
36	S-104	STORMWATER TREATMENT FACILITY SECTIONS I
37	S-105	STORMWATER TREATMENT FACILITY SECTIONS II
38	S-106	STORMWATER TREATMENT FACILITY DETAILS
PROCESS AND INSTRUMENTATION		
39	I-001	INSTRUMENTATION LEGEND AND NOTES
40	I-101	INSTRUMENTATION DETAILS
41	I-201	P&ID STORMWATER LIFT STATIONS
MECHANICAL (PROCESS)		
42	M-001	MECHANICAL ABBREVIATIONS AND NOTES
43	M-101	STORMWATER LIFT STATION EAST PLAN AND SECTION
44	M-102	STORMWATER LIFT STATION WEST PLAN AND SECTION
45	M-500	MECHANICAL DETAILS
ELECTRICAL		
46	E-001	ELECTRICAL ABBREVIATIONS AND NOTES
47	E-002	ELECTRICAL LEGEND - I
48	E-003	ELECTRICAL LEGEND - II
49	E-100	ELECTRICAL OVERALL SITE PLAN
50	E-101	STORMWATER LIFT STATION EAST PLAN
51	E-102	STORMWATER LIFT STATION WEST PLAN
52	E-201	ELECTRICAL DETAILS
53	E-301	ELECTRICAL SINGLE LINE DIAGRAMS
54	E-302	EAST LIFT STATION ELECTRICAL CONTROL SCHEMATIC
55	E-303	WEST LIFT STATION ELECTRICAL CONTROL SCHEMATIC
56	E-304	PANELBOARD SCHEDULES

* DENOTES DRAWINGS NOT INCLUDED IN THIS SUBMITTAL



LOCATION MAP
SCALE: NTS



VICINITY MAP
SCALE: NTS

PROJECT PERSONNEL

PORT OF PORT TOWNSEND

MATTHEW KLONTZ: CAPITAL PROJECTS DIRECTOR
AND PORT ENGINEER
2701 JEFFERSON STREET
PORT TOWNSEND, WA 98368
PHONE: (360) 379-5025

KENNEDY JENKS

SAMANTHA KARPA, PE: PROJECT MANAGER
32001 32ND AVENUE SUITE 300
FEDERAL WAY, WA
98001-9801
PHONE: (253) 835-6402



RECEIVED

AUG 13 2024

CITY OF PORT TOWNSEND
DSD

60% SUBMITTAL

PRELIMINARY DESIGN PHASE
NOT FOR CONSTRUCTION

THIS DOCUMENT IS AN INTERIM DOCUMENT AND NOT SUITABLE FOR CONSTRUCTION. AS AN INTERIM DOCUMENT, IT MAY CONTAIN DATA THAT IS POTENTIALLY INACCURATE OR INCOMPLETE AND IS NOT TO BE RELIED UPON WITHOUT THE EXPRESS WRITTEN CONSENT OF THE PREPARED.

NO	REVISION	DATE	BY

SCALES
1" = 100'
0" = 25mm
IF THIS BAR IS NOT DIMENSION SHOWN, ADJUST SCALES ACCORDINGLY.

THIS PRELIMINARY DOCUMENT IS NOT FOR CONSTRUCTION. IT IS RELEASED UNDER THE AUTHORITY OF SAMANTHA KARPA 21024598 JUNE 2024

DESIGNED	KJ
DRAWN	CEC
CHECKED	SNK

PORT OF PORT TOWNSEND
PORT TOWNSEND, WASHINGTON
BOAT HAVEN MARINA
STORMWATER IMPROVEMENTS PHASE 2



COVER, LOCATION & VICINITY MAPS,
AND DRAWING INDEX

SCALE	NTS
JOB NO.	2297203.01
DATE	JUNE 2024
SHEET	1 OF 1
	G-001

NOTES

- GENERAL**
- THIS PROJECT IS WITHIN CITY OF PORT TOWNSEND, WASHINGTON.
 - ALL WORK SHALL BE PERFORMED ACCORDING TO PROJECT SPECIFICATIONS.
 - A PRE-EXISTING SITE CONDITION VIDEO SHALL BE PROVIDED BY THE CONTRACTOR AND SHALL SHOW EXISTING CONDITIONS OF ALL CONCRETE, ASPHALT, LANDSCAPED AREAS, BUILDING EXTERIOR, ETC. SURROUNDING THE CONSTRUCTION AREAS. VIDEO SHALL BE SUBMITTED TO THE OWNER PRIOR TO BREAKING GROUND. THE CONTRACTOR SHALL TAKE ALL PRECAUTIONARY MEASURES NECESSARY TO PROTECT EXISTING IMPROVEMENTS WHICH ARE TO REMAIN IN PLACE FROM DAMAGE. ALL IMPROVEMENTS DAMAGED BY THE CONTRACTOR'S OPERATIONS SHALL BE EXPEDITIOUSLY REPAIRED OR RECONSTRUCTED AT THE CONTRACTOR'S EXPENSE WITHOUT ADDITIONAL COMPENSATION.
 - CONTRACTOR SHALL RESTORE ALL SURVEY MONUMENTS THAT ARE DAMAGED OR DESTROYED DURING CONSTRUCTION.
 - OBSERVATIONS OF WORK IN PROGRESS DURING SITE VISITS SHALL NOT ALTER THE REQUIREMENTS OF THE CONTRACT DOCUMENTS.
- UTILITIES**
- LOCATIONS OF UNDERGROUND UTILITIES SHOWN ON THE DRAWINGS WERE OBTAINED FROM AVAILABLE RECORDS AND ARE SHOWN IN THEIR APPROXIMATE LOCATION. THERE IS NO GUARANTEE THAT ALL EXISTING PIPELINES AND OBSTRUCTIONS ARE SHOWN OR THAT LOCATIONS INDICATED ARE ACCURATE. PRIOR TO THE START OF CONSTRUCTION, THE CONTRACTOR SHALL POthOLE TO DETERMINE ACTUAL LOCATION AND ELEVATION OF ALL EXISTING UTILITIES IN AND AROUND THE AREAS OF NEW CONSTRUCTION.
 - THE CONTRACTOR SHALL TAKE ALL PRECAUTIONARY MEASURES NECESSARY TO PROTECT ALL REMAINING EXISTING UTILITIES WHETHER SHOWN OR NOT SHOWN.
 - PRIOR TO ANY CONNECTION TO AN EXISTING UTILITY, THE CONTRACTOR SHALL COORDINATE WITH THE UTILITY OWNER.
 - PRIOR TO ANY EXCAVATION IN THE VICINITY OF ANY EXISTING UNDERGROUND FACILITIES, INCLUDING ALL WATER, SEWER, STORM DRAIN, GAS, PETROLEUM PRODUCTS, OR OTHER PIPELINES; ALL BURIED ELECTRIC POWER, COMMUNICATIONS, OR TELEVISION CABLES; ALL TRAFFIC SIGNAL AND STREET LIGHTING FACILITIES; AND ALL ROADWAY, STATE HIGHWAY, AND RAILROAD RIGHTS-OF-WAY, THE CONTRACTOR SHALL NOTIFY THE RESPECTIVE AUTHORITIES REPRESENTING THE OWNERS OR AGENCIES RESPONSIBLE FOR SUCH FACILITIES TO FACILITATE A TIMELY MANNER OF WORK SO THAT A REPRESENTATIVE OF SAID OWNERS OR AGENCIES CAN BE PRESENT DURING SUCH WORK IF THEY SO DESIRE. IN THE CASE OF THE UNDERGROUND UTILITY SERVICE ALERT CENTER, THIS NOTICE WILL GIVE THEM TIME TO MARK THE LOCATION OF THE UTILITIES. THE CONTRACTOR SHALL ALSO NOTIFY UNDERGROUND SERVICES ALERT (USA) AT (811) IN ACCORDANCE WITH THE SPECIFICATIONS TO FACILITATE A TIMELY MANNER OF WORK, PRIOR TO SUCH EXCAVATION.

CALLOUTS AND SHORTHAND SYMBOLS

- DIRECTION OF FLOW
- SHEET KEYNOTE
- CENTERLINE
- PLATE
- DIAMETER
- APPROXIMATELY
- ANGLE
- WATER/FLUID SURFACE
- BUILDING GRID LABEL OR ACCESSORY NUMBER
- DOOR
- ROOM
- WALL
- WINDOW

REVISION SYMBOLS

CLOUDED AREA INDICATES CHANGED INFORMATION. NUMBER IN TRIANGLE INDICATES THE DRAWING REVISION AND MATCHES WITH REVISION INFORMATION IN THE REVISION BLOCK WITHIN THE DRAWING BORDER.

SYMBOLOLOGY

- NORTH ARROW
- NEW
- FUTURE
- EXISTING LINEAR ELEMENTS TO BE REMOVED OR DEMOLISHED
- EXISTING NON-LINEAR ELEMENTS TO BE REMOVED OR DEMOLISHED
- CENTERLINE
- MATCHLINE CONTINUED ON DRAWING
- MATCHLINE
- BREAK LINE
- NATIVE EARTH (IN SECTION)
- ENGINEERED FILL (IN SECTION)
- LANDSCAPE FILL (IN PLAN AND SECTION)
- SAND OR GROUT (IN PLAN AND SECTION)
- GRAVEL (IN PLAN AND SECTION)
- AGGREGATE BASE (IN PLAN AND SECTION)
- CRUSHED ROCK (IN PLAN AND SECTION)
- CONCRETE (IN PLAN AND SECTION)
- GRATING (IN PLAN)
- CHECKER PLATE (IN PLAN)
- MASONRY (IN SECTION)
- STEEL (IN SECTION)
- UTILITY CROSSING UNDERNEATH
- UTILITY CROSSING OVER

CROSS-REFERENCING SYMBOLS

- FOUND ON DRAWING WHERE DETAIL SECTION, OR ELEVATION IS CALLED OUT
 - FOUND ON DRAWING WHERE DETAIL SECTION, OR ELEVATION IS DRAWN
 - SECTION LETTER
 - SECTION LETTER
 - LETTERS USED WHEN MORE THAN ONE ELEVATION IS DRAWN WITHIN A SINGLE ROOM
 - ELEVATION NUMBER
 - INTERIOR ELEVATION A
 - STANDARD DETAIL NUMBER
 - STANDARD DETAIL NUMBER
- NOTE: STANDARD DETAILS ARE LOCATED WITHIN THEIR RESPECTIVE DISCIPLINE, IMMEDIATELY FOLLOWING THE GENERAL ABBREVIATIONS, NOTES, AND LEGEND SHEETS.

LOADING CRITERIA



60% SUBMITTAL

PRELIMINARY DESIGN PHASE
NOT FOR CONSTRUCTION

THIS DOCUMENT IS AN INTERIM DOCUMENT AND NOT SUITABLE FOR CONSTRUCTION. AS AN INTERIM DOCUMENT, IT MAY CONTAIN DATA THAT IS POTENTIALLY INACCURATE OR INCOMPLETE AND IS NOT TO BE RELIED UPON WITHOUT THE EXPRESS WRITTEN CONSENT OF THE PREPARED.

NO.	REVISION	DATE	BY

SCALES

0 25mm

IF THIS BAR IS NOT DIMENSION SHOWN, ADJUST SCALES ACCORDINGLY.

THIS PRELIMINARY DOCUMENT IS NOT FOR CONSTRUCTION. IT IS RELEASED UNDER THE AUTHORITY OF SAMANTHA KARPA 21624536 JUNE 2024

DESIGNED	KJ
DRAWN	DEC
CHECKED	SNK

PORT OF PORT TOWNSEND
PORT TOWNSEND, WASHINGTON
BOAT HAVEN MARINA
STORMWATER IMPROVEMENTS PHASE 2

Kennedy Jenks

GENERAL NOTES AND LEGEND

SCALE	NTS
JOB NO.	2287002-01
DATE	JUNE 2024
SHEET	3 OF 11
	G-003

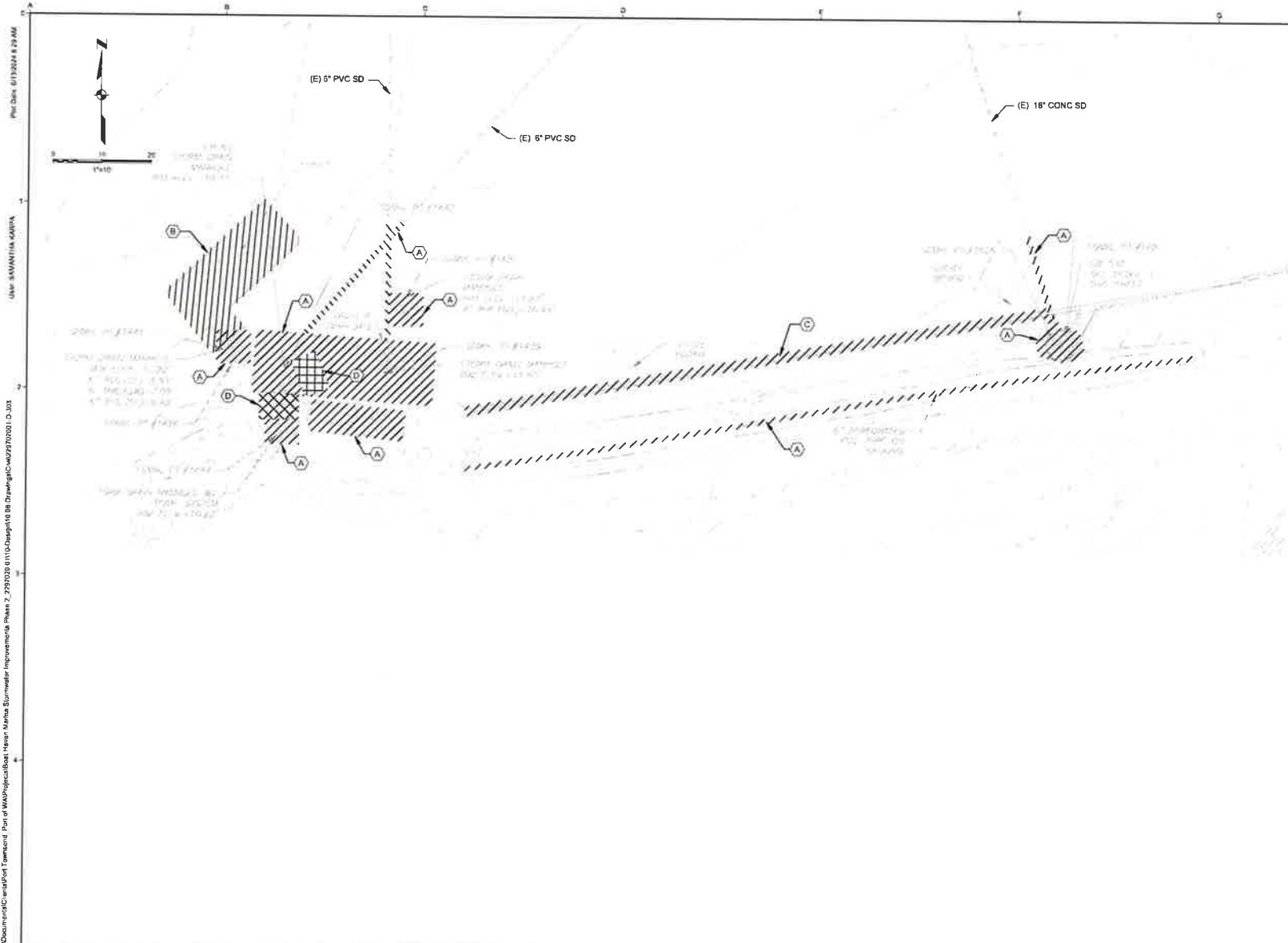

GENERAL SHEET NOTES

1. UTILITY LOCATIONS SHOWN IN DRAWINGS ARE APPROXIMATE AND MAY NOT INCLUDE ALL UTILITIES OR FULL EXTENT OF UTILITY LINES.
2. STRUCTURES SHOWN MAY BE COVERED BY SOIL OR OTHER DEBRIS. CONTRACTOR IS RESPONSIBLE FOR LOCATING ALL EXISTING STRUCTURES AND UTILITIES.
3. ALL EXISTING INFRASTRUCTURE OUTSIDE OF THE GRADING LIMITS SHALL BE PROTECTED IN PLACE.
4. ALL ITEMS NOT IDENTIFIED TO BE REMOVED HEREON SHALL BE PROTECTED IN PLACE.
5. ALL EXISTING ELECTRICAL POLES AND EQUIPMENT SHALL BE PROTECTED IN PLACE.
6. DEMOLITION EXTENTS INDICATED IN DRAWINGS ARE THE MINIMUM REQUIRED TO COMPLETE THE WORK. EXTENTS OF DEMOLITION REFLECTED IN THE CONTRACTOR'S BID SHALL INCORPORATE DEMOLITION MEANS AND METHODS.

DEMOLITION KEYNOTES

- A. DEMOLISH STORM DRAIN STRUCTURES (CATCH BASINS, VAULTS, MANHOLES, PIPING, ETC)
- B. DEMOLISH CONCRETE PAVEMENT
- C. DEMOLISH CONCRETE CURB AND GUTTER
- D. DEMOLISH POWER VAULTS, CONDUIT, AND WIRES

60% SUBMITTAL

PRELIMINARY DESIGN PHASE
 NOT FOR CONSTRUCTION

THIS DOCUMENT IS AN INTERIM DOCUMENT AND NOT SUITABLE FOR CONSTRUCTION. AS AN INTERIM DOCUMENT, IT MAY CONTAIN DATA THAT IS POTENTIALLY INACCURATE OR INCOMPLETE AND IS NOT TO BE RELIED UPON WITHOUT THE EXPRESS WRITTEN CONSENT OF THE PREPARER.

NO	REVISION	DATE	BY

SCALES

0 1" = 25mm

IF THIS BAR IS NOT DIMENSION SHOWN, ADJUST SCALES ACCORDINGLY.

THIS PRELIMINARY DOCUMENT IS NOT FOR CONSTRUCTION. IT IS RELEASED UNDER THE AUTHORITY OF:
 SAMANTHA KARPA
 21024598
 JUNE 2024

DESIGNED	SNK
DRAWN	CEC
CHECKED	SNK

PORT OF PORT TOWNSEND
 PORT TOWNSEND, WASHINGTON

**BOAT HAVEN MARINA
 STORMWATER IMPROVEMENTS PHASE 2**

K Kennedy Jenks

VAULT 4 DEMOLITION

SCALE: 1" = 10'

JOB NO: 228P203-01

DATE: JUNE 2024

SHEET # OF: —























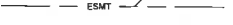

























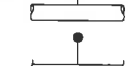
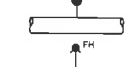
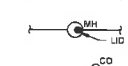





























D-303

P:\New\pm-bonlay.com\pwp\Documents\Cad\Port Townsend - Port of MW\Projects\Boat Haven Marina - Stormwater Improvements Phase 2_20240208 (1110)DWG\110 D-303.dwg
 User: SAMANTHA.KARPA
 Plot Date: 6/13/2024 8:29 AM

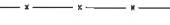
Plot Date: 01/13/2024 8:00 AM

USER: SAMANTHA.KARPA

Path: \\pwr-01b-jenkins.com\Users\pwr-01b-jenkins\Documents\Civil\Port Townsend\Port of Washington\Boat Haven Marina Stormwater Improvements\Phase 2\2024\01\13\DWG\PLN\02-Civil\Legend\02-C-002

GEOTECHNICAL SYMBOLS  SOIL BORING LOCATION  TEST PIT LOCATION  MONITORING WELL	TOPOGRAPHY AND MAPPING SYMBOLS  MAJOR CONTOURS  MINOR CONTOURS  TOP OF SLOPE  TOE OF SLOPE  PROPERTY LINE  RIGHT-OF-WAY LINE  GRADE BREAK  RIDGE LINE  EASEMENT LINE  TEMPORARY EASEMENT LINE  TRAIL OR DIRT ROAD  FLOW LINE  FLOOD HAZARD AREA  EDGE OF WETLANDS  RAILROAD  SITE OR RETAINING WALL  GUARDRAIL (PERMANENT)  LIMITS OF GRADING  LIMITS OF EXCAVATION	EXISTING FEATURES  VEGETATION  TREE (SIZE AND TYPE)  WELL  POWER POLE  GUY LINE AND ANCHOR  MAILBOX  TRAFFIC SIGNAL BOX OR POLE  SIGN  TELEPHONE BOX  COMMUNICATION/CATV BOX  HOSE BIB  HOSE RACK  WATER BOX/METER  BACKFLOW PREVENTER  MAN-HOLE OR VAULT  FIRE HYDRANT	PIPING AND UTILITIES  AVALANCHE VALVE (IN PLAN) LOCATE ON SIDE SHOWN  AVALANCHE VALVE (IN PROFILE)  BLOWOFF (IN PLAN) LOCATE ON SIDE SHOWN  BLOWOFF (IN PROFILE)  FIRE HYDRANT (IN PLAN)  MAN-HOLE (IN PLAN)  CLEANOUT TO GRADE (IN PLAN)	ROADWORK AND PAVING NOTES 1. PAVING PATTERNS MAY ONLY APPEAR IN PORTIONS OF PAVED AREAS TO DEFINE LIMITS OF PAVING. 2. SEE ALSO GENERAL LEGEND FOR ADDITIONAL PAVING PATTERNS.  ASPHALT (IN PLAN AND SECTION)  CONCRETE CURB  CONCRETE CURB AND CUTTER  DRIVEWAY/ACCESS RAMP  WELDED WIRE FABRIC (IN SECTION)
CORROSION CONTROL SYMBOLS  ELECTROLYSIS TEST STATION  CATHODIC TEST STATION  CORROSION TEST STATION  CASING TEST STATION  INSULATING JOINT TEST STATION  FOREIGN PIPELINE TEST STATION  CURRENT SPAN TEST STATION	EXISTING UTILITIES  WATER LINE  STORM DRAIN  SANITARY SEWER	PROPOSED FEATURES  MANHOLE  STORM DRAIN CENTER LINE		CONTROL SYMBOLS  BENCHMARK  SITE COORDINATES (SEE TABLE ON DRAWINGS)  SITE COORDINATES  CONTROL POINT  MILESTONE  FINISHED ELEVATION/GRADE  EXISTING ELEVATION/GRADE  CURVE DATA (SEE TABLE ON DRAWINGS)
GENERAL CIVIL SYMBOLS  SLOPE ON PAVED SURFACE OR PIPE  BERM SLOPE (HORZ TO VERT)  SURFACE FLOW DIRECTION	SCALES  1" = 20'  1" = 20mm IF THIS BAR IS NOT DIMENSION SHOWN, ADJUST SCALES ACCORDINGLY	DESIGNED KU DRAWN CEC CHECKED SAK	PORT OF PORT TOWNSEND PORT TOWNSEND, WASHINGTON BOAT HAVEN MARINA STORMWATER IMPROVEMENTS PHASE 2  Kennedy Jenks	CIVIL LEGEND  FENCE (CHAIN LINK)  FENCE (WOOD)  FENCE (SWING GATE)  PROTECTIVE BARRIER (REMOVABLE)  STRUCTURE  STRUCTURE (BELOW GRADE)

60% SUBMITTAL			
PRELIMINARY DESIGN PHASE			
NOT FOR CONSTRUCTION			
THIS DOCUMENT IS AN INTERIM DOCUMENT AND NOT SUITABLE FOR CONSTRUCTION. AS AN INTERIM DOCUMENT, IT MAY CONTAIN DATA THAT IS POTENTIALLY INACCURATE OR INCOMPLETE AND IS NOT TO BE RELIED UPON WITHOUT THE EXPRESS WRITTEN CONSENT OF THE PREPARER.			
NO.	REVISION	DATE	BY

NO.	REVISION	DATE	BY
-----	----------	------	----

THIS PRELIMINARY DOCUMENT IS NOT FOR CONSTRUCTION. IT IS RELEASED UNDER THE AUTHORITY OF SAMANTHA KARPA 7/16/2024

DESIGNED KU
 DRAWN CEC
 CHECKED SAK

PORT OF PORT TOWNSEND
 PORT TOWNSEND, WASHINGTON
BOAT HAVEN MARINA
STORMWATER IMPROVEMENTS PHASE 2
 Kennedy Jenks

CIVIL LEGEND

SCALE: NTS
 JOB NO: 2207020-01
 DATE: JUNE 2024
 SHEET 10 OF --
C-002

Plot Date: 6/13/2024 7:11 PM
 User: SAMANTHA.KARPA
 File: W:\Projects\Boat Haven Marina Stormwater Improvements Phase 2_2397020.dwg Design\10-00-Drawings\C-101-ERS-20240613.dwg

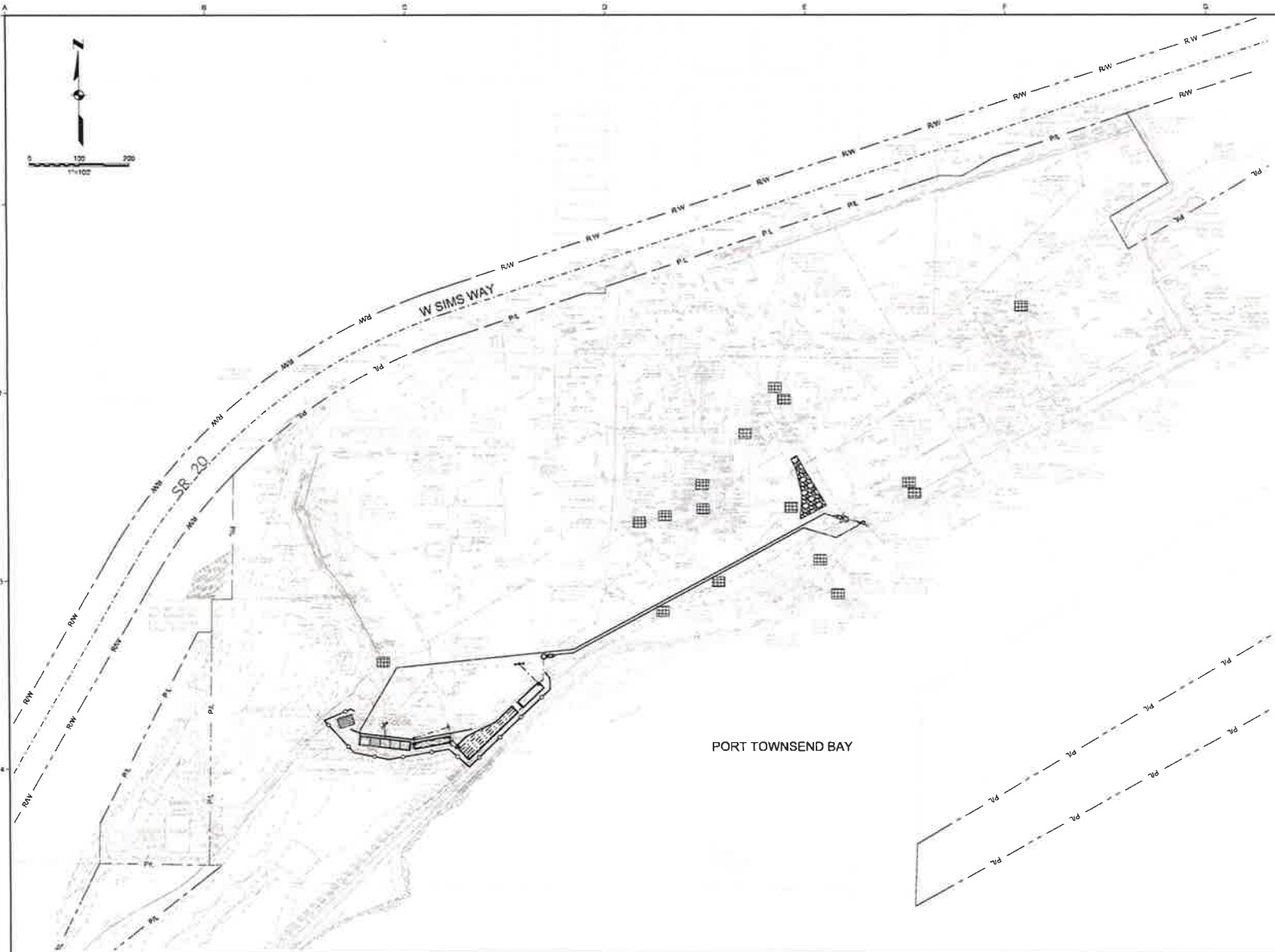

TESC NOTES

1. THE CONTRACTOR SHALL CONDUCT ALL EROSION AND SEDIMENT CONTROL PRACTICES IN ACCORDANCE WITH THE SPECIFICATIONS AND CONSTRUCTION SWPPP. SEE SPECIFICATION SECTION 01 57 00.
2. THE IMPLEMENTATION OF TESC PLANS AND THE CONSTRUCTION, MAINTENANCE, REPLACEMENT, UPGRADING, AND REMOVAL OF TESC FACILITIES SHALL BE THE RESPONSIBILITY OF THE CONTRACTOR UNTIL ALL CONSTRUCTION IS COMPLETE AND APPROVED.
3. CONTRACTOR SHALL PERFORM ALL TESC MEASURES AS NECESSARY TO ENSURE NO AGGREGATE, PAVEMENT, SOIL, OR OTHER MATERIALS ARE TRACKED OUT OF THE WORK AREA. TESC FACILITIES SHALL BE UPGRADED AS NECESSARY TO ENSURE THAT SEDIMENT AND SEDIMENT LADEN WATER DOES NOT LEAVE THE DESIGNATED WORK AREA.
4. CONTRACTOR SHALL INSTALL STORMWATER INLET PROTECTION FOR ALL INLETS WITHIN THE WORK LIMITS AND WITHIN 100 FEET OF THE WORK LIMITS AND ALL HAUL ROUTES. SEE DETAIL 1 HEREON. INLET PROTECTION SHALL BE MAINTAINED UNTIL THE INLET IS DEMOLISHED (IF CALLED FOR) OR UNTIL ALL CONSTRUCTION IS COMPLETE AND APPROVED, AS APPLICABLE.
5. AT NO TIME SHALL MORE THAN 1 FOOT OF SEDIMENT BE ALLOWED TO ACCUMULATE WITHIN THE STORMWATER INLET PROTECTION.
6. ALL PROPOSED TESC FACILITIES SHALL BE SUBMITTED TO THE ENGINEER FOR REVIEW.
7. ALL TESC FACILITIES SHALL BE CONSTRUCTED PRIOR TO CONSTRUCTION ACTIVITIES AND IN SUCH A MANNER AS TO ENSURE THAT CONSTRUCTION STORMWATER DOES NOT ENTER THE DRAINAGE SYSTEM OR ADJACENT WATER BODY, OR VIOLATE APPLICABLE WATER QUALITY STANDARDS.
8. STABILIZATION SHALL BE PROVIDED FOR STOCKPILE(S) AND UPGRADED AS NECESSARY TO MINIMIZE SEDIMENT LOSSES, AS SHOWN IN DETAIL 2/C-102.
9. STOCKPILE(S) SHALL BE SURROUNDED BY ECOLOGY BLOCKS, BARRICADES, HIGH VISIBILITY FENCING AND/OR OTHER MEASURES TO PROVIDE FOR PUBLIC, PORT, AND CONTRACTOR SAFETY.
10. TRACK OUT FROM THE STOCKPILE SHALL BE MINIMIZED, AND PRIOR TO FINAL CLOSEOUT, STOCKPILE AREA SHALL BE CLEARED OF ACCUMULATED OR STRAY SEDIMENT.
11. TRACK OUT ONTO PUBLIC ROADS SHALL BE PREVENTED. IN THE EVENT IT OCCURS, A SWEEPER TRUCK OR OTHER TESC MEASURE SHALL BE USED TO COLLECT AND REMOVE ANY TRACKED OUT SEDIMENT FROM PUBLIC ROADS BY THE END OF THE WORK DAY.

LEGEND

	CATCH BASIN FILTER	1 C-102
	CONCRETE WASHOUT	5 C-102
	CONSTRUCTION ENTRANCE	3 C-102
	SILT FENCE	4 C-102

60% SUBMITTAL

PRELIMINARY DESIGN PHASE
NOT FOR CONSTRUCTION

THIS DOCUMENT IS AN INTERIM DOCUMENT AND NOT SUITABLE FOR CONSTRUCTION. AS AN INTERIM DOCUMENT, IT MAY CONTAIN DATA THAT IS POTENTIALLY INACCURATE OR INCOMPLETE AND IS NOT TO BE RELIED UPON WITHOUT THE EXPRESS WRITTEN CONSENT OF THE PREPARER.

NO.	REVISION	DATE	BY

SCALES

0" = 100'

0" = 20mm

IF THIS BAR IS NOT DIMENSION SHOWN, ADJUST SCALES ACCORDINGLY.

DESIGNED: SNK
DRAWN: CEC
CHECKED: SNK

PORT OF PORT TOWNSEND
PORT TOWNSEND, WASHINGTON
BOAT HAVEN MARINA
STORMWATER IMPROVEMENTS PHASE 2

Kennedy Jenks

EROSION AND SEDIMENT CONTROL
PLAN AND NOTES

SCALE: 1" = 100'
JOB NO: 2397020-01
DATE: JUNE 2024
SHEET 11 OF 11
C-101

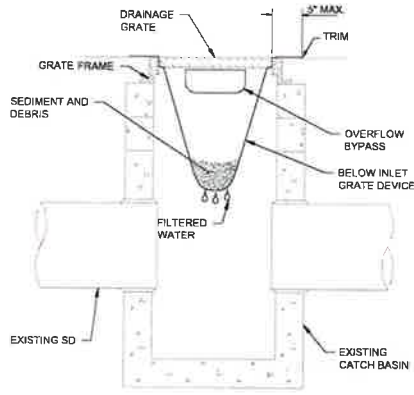

1 CATCH BASIN FILTER
SCALE: NTS

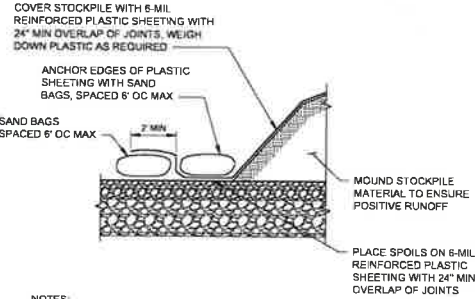

- NOTES:**
1. RIPS AND/OR TEARS IN THE PLASTIC SHEETING SHALL BE REPAIRED IN A TIMELY MANNER PER SPECIFICATION SECTION 01 57 00.
 2. MATERIAL SHALL BE STOCKPILED NO STEEPER THAN 1 TO 1 SLOPE.
 3. THE TOE OF THE STOCKPILE SHALL BE NO CLOSER THAN 2-FT FROM THE EDGE OF EXCAVATION.
 4. STOCKPILE HEIGHT SHALL NOT EXCEED 10-FT.

2 STOCKPILE
SCALE: NTS

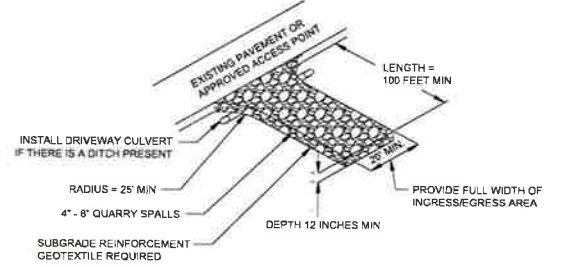

- NOTES:**
1. IT IS RECOMMENDED THAT THE ENTRANCE BE CROWNED SO THAT RUNOFF DRAINS OFF OF THE PAD.
 2. RECYCLED CONCRETE CEMENT OR ASPHALT RUBBLE CANNOT BE USED FOR QUARRY SPALLS.

3 CONSTRUCTION ENTRANCE AND EXIT
SCALE: NTS

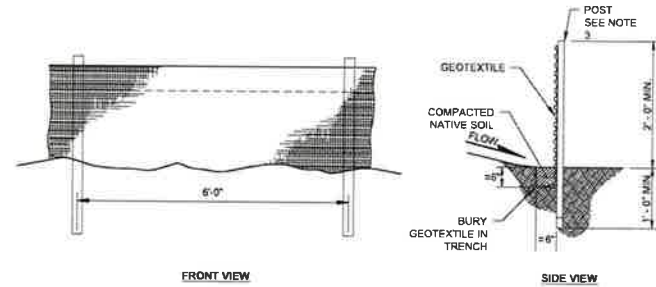

4 SILT FENCE
SCALE: NTS

- NOTES:**
1. SILT FENCE EXTENTS SHOWN ON THE PLANS ARE APPROXIMATE. CONTRACTOR IS RESPONSIBLE FOR MODIFYING THE EXTENTS OF THE SILT FENCE AS NECESSARY TO PREVENT SEDIMENT AND SEDIMENT-LADEN RUNOFF FROM LEAVING THE CONSTRUCTION SITE.
 2. REFER TO SPECIFICATIONS SECTION 01 57 13 FOR COMPLETE EROSION AND SEDIMENT CONTROL REQUIREMENTS.
 3. BURY BOTTOM OF FILTER FABRIC 8\"/>

SEDIMENT FENCE SPACING

SLOPE	SPACING
<10%	300 FT.
<15%	150 FT.
<20%	100 FT.
<30%	50 FT.
<50%	25 FT.
STOCK PILE	25 FT.
SLOPE >50%	25 FT.

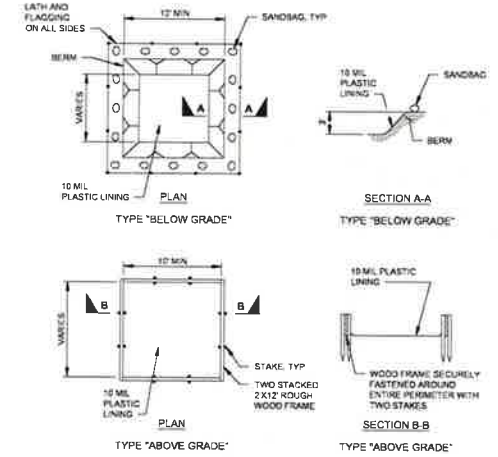
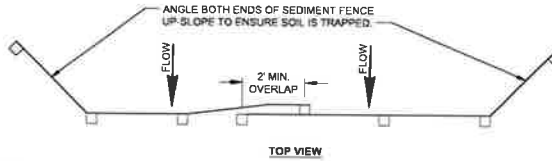

- NOTES:**
1. ACTUAL LAYOUT SHALL BE DETERMINED IN THE FIELD.
 2. A CONCRETE WASHOUT SIGN SHALL BE INSTALLED WITHIN 30 FT. OF THE TEMPORARY CONCRETE WASHOUT FACILITY. SEE ECOLOGY BMP C154 FOR FURTHER DETAILS.

5 CONCRETE WASHOUT
SCALE: NTS

60% SUBMITTAL

PRELIMINARY DESIGN PHASE
NOT FOR CONSTRUCTION

THIS DOCUMENT IS AN INTERIM DOCUMENT AND NOT SUITABLE FOR CONSTRUCTION. AS AN INTERIM DOCUMENT, IT MAY CONTAIN DATA THAT IS POTENTIALLY INACCURATE, INCOMPLETE, AND IS NOT TO BE RELIED UPON WITHOUT THE EXPRESS WRITTEN CONSENT OF THE PREPARED.

NO.	REVISION	DATE	BY

SCALES
0 = 1'
0 = 25mm
IF THIS BAR IS NOT DIMENSION SHOWN, ADJUST SCALES ACCORDINGLY.

THIS PRELIMINARY DOCUMENT IS NOT FOR CONSTRUCTION. IT IS RELEASED UNDER THE AUTHORITY OF SAMANTHA KARPA 21024598 JUNE 2024

DESIGNED	SNK
DRAWN	CEC
CHECKED	SNK

PORT OF PORT TOWNSEND
PORT TOWNSEND, WASHINGTON
**BOAT HAVEN MARINA
STORMWATER IMPROVEMENTS PHASE 2**



EROSION AND SEDIMENT CONTROL DETAILS

SCALE	NTS
JOB NO.	2297020 01
DATE	JUNE 2024
SHEET	12 OF 11
	C-102

Plot 0346 - 6/13/2024 11:31 AM
 User: SAMANTHA KARRA
 Path: W:\Projects\2024\Port of Townsend\Port of Townsend Stormwater Improvements Phase 2\2252020 0110\Design\10 00\Drawings\2024\20240613\20240613-C-203

- GENERAL SHEET NOTES**
- UTILITY LOCATIONS SHOWN IN DRAWINGS ARE APPROXIMATE AND MAY NOT INCLUDE ALL UTILITIES OR FULL EXTENT OF UTILITY LINES.
 - SEE DETAIL 51C-501 FOR UTILITIES ENCOUNTERED WITH 12" OR LESS CLEARANCE WITH PROPOSED FORCEMAIN.
 - REMOVE AND REPLACE EXISTING SDMH.

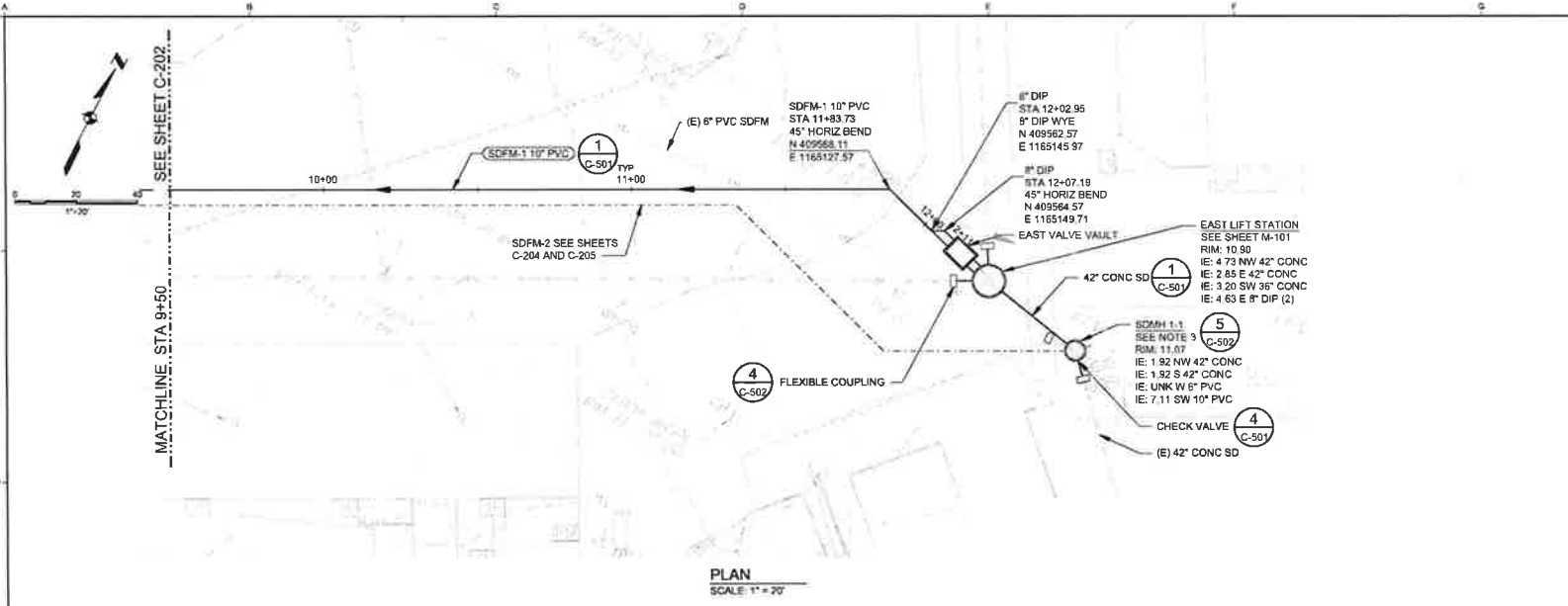

PLAN
SCALE: 1" = 20'

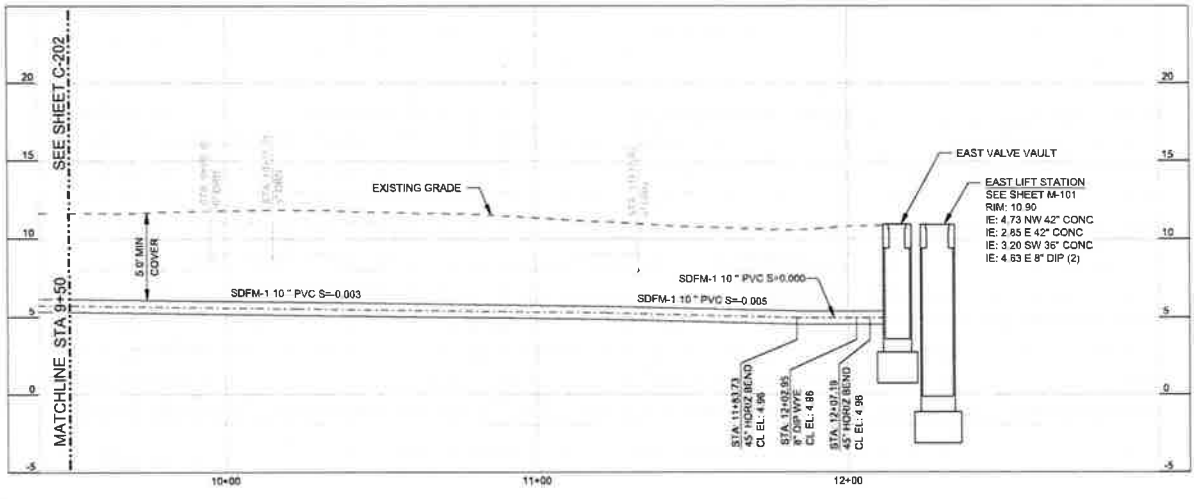

PROFILE
SCALE: 1" = 20'

60% SUBMITTAL

PRELIMINARY DESIGN PHASE
 NOT FOR CONSTRUCTION
 THIS DOCUMENT IS AN INTERIM DOCUMENT AND NOT SUITABLE FOR CONSTRUCTION. AS AN INTERIM DOCUMENT, IT MAY CONTAIN DATA THAT IS POTENTIALLY INACCURATE OR INCOMPLETE AND IS NOT TO BE RELIED UPON WITHOUT THE EXPRESS WRITTEN CONSENT OF THE PREPARED.

NO.	REVISION	DATE	BY



THIS PRELIMINARY DOCUMENT IS NOT FOR CONSTRUCTION. IT IS RELEASED UNDER THE AUTHORITY OF SAMANTHA KARRA 21024596 JUNE 2024

DESIGNED	SNK
DRAWN	CEC
CHECKED	SNK

PORT OF PORT TOWNSEND
 PORT TOWNSEND, WASHINGTON
 BOAT HAVEN MARINA
 STORMWATER IMPROVEMENTS PHASE 2

STORMWATER CONVEYANCE
 PLAN AND PROFILE - SDFM-1
 STA 9+50 TO END

SCALE	1" = 20'
JOB NO	2297020 01
DATE	JUNE 2024
SHEET	13 OF --
	C-203

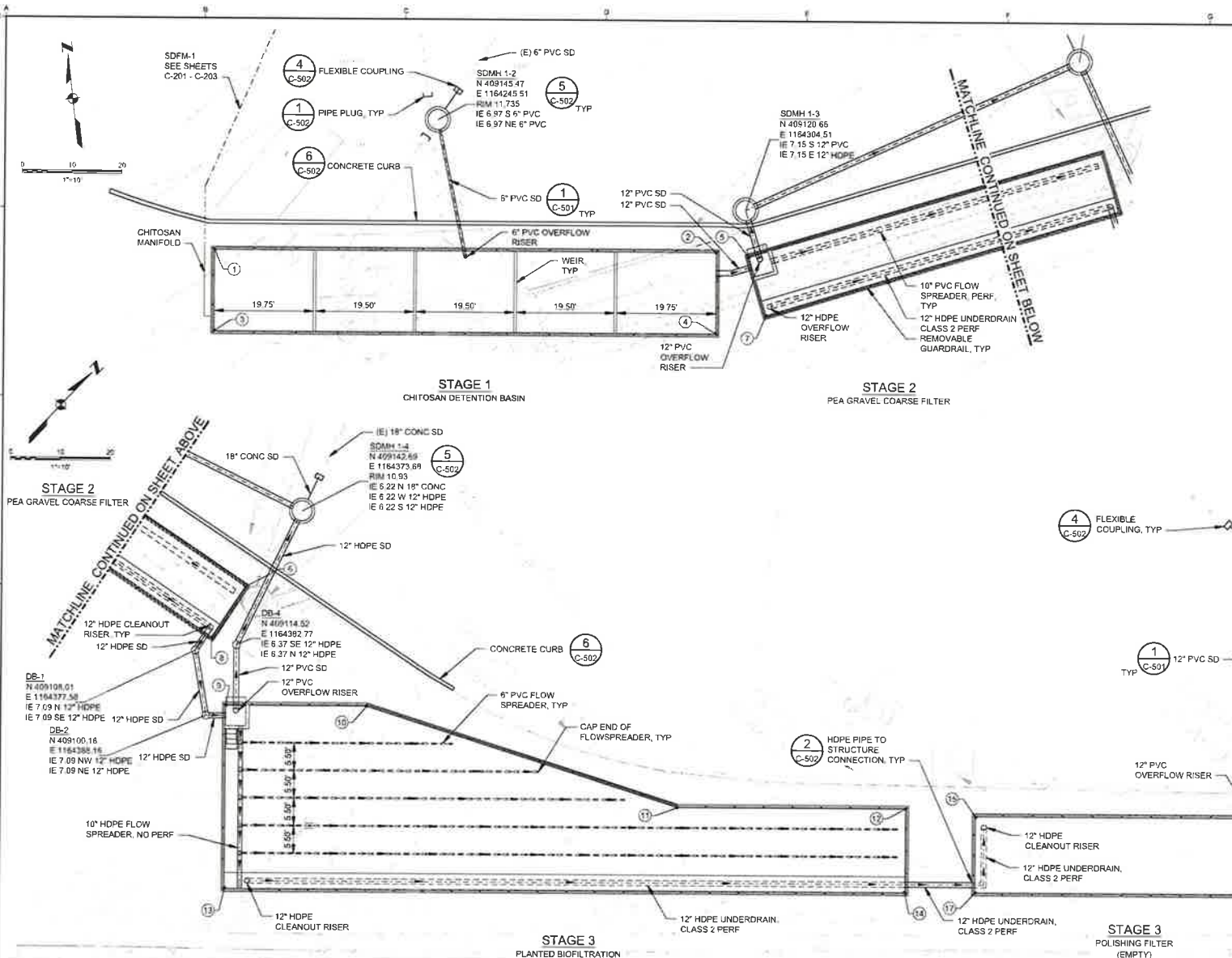

TREATMENT SYSTEM COORDINATES TABLE			
CONTROL POINT NO.	NORTHING	EASTING	DESCRIPTION
1	409124.81	1164188.45	NW CORNER STAGE 1
2	409112.89	1164297.76	NE CORNER STAGE 1
3	409108.73	1164186.54	SW CORNER STAGE 1
4	409097.00	1164295.89	SE CORNER STAGE 1
5	409111.27	1164304.14	NW CORNER STAGE 2
6	409123.99	1164378.03	NE CORNER STAGE 2
7	409099.45	1164306.23	SW CORNER STAGE 2
8	409112.17	1164378.11	SE CORNER STAGE 2
9	409104.39	1164389.88	NW CORNER STAGE 3
10	409123.77	1164409.96	CORNER STAGE 3
11	409152.31	1164468.53	CORNER STAGE 3
12	409183.70	1164501.42	NE CORNER STAGE 3
13	409078.12	1164454.77	SW CORNER STAGE 3
14	409171.81	1164512.83	SE CORNER STAGE 3
15	409192.34	1164512.57	NW CORNER STAGE 4
16	409232.41	1164554.43	NE CORNER STAGE 4
17	409181.48	1164522.54	SW CORNER STAGE 4
18	409221.56	1164554.83	SE CORNER STAGE 4

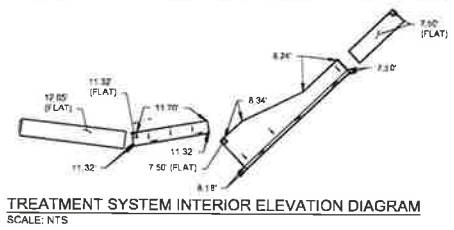

60% SUBMITTAL

PRELIMINARY DESIGN PHASE
NOT FOR CONSTRUCTION

THIS DOCUMENT IS AN INTERIM DOCUMENT AND NOT SUITABLE FOR CONSTRUCTION. AS AN INTERIM DOCUMENT, IT MAY CONTAIN DATA THAT IS POTENTIALLY INACCURATE OR INCOMPLETE AND IS NOT TO BE RELIED UPON WITHOUT THE EXPRESS WRITTEN CONSENT OF THE PREPARER.

NO.	REVISION	DATE	BY

SCALES

1" = 10'

1/8" = 10'

IF THIS BAR IS NOT DIMENSION SHOWN, ADJUST SCALES ACCORDINGLY

DESIGNED: SNK
DRAWN: CEC
CHECKED: SNK

PORT OF TOWNSEND
PORT TOWNSEND, WASHINGTON
BOAT HAVEN MARINA
STORMWATER IMPROVEMENTS PHASE 2

Kennedy Jenks

STORMWATER TREATMENT PLAN

SCALE: 1" = 10'

JOB NO: 22972021.01
DATE: JUNE 2024
SHEET 20 OF 21
C-303

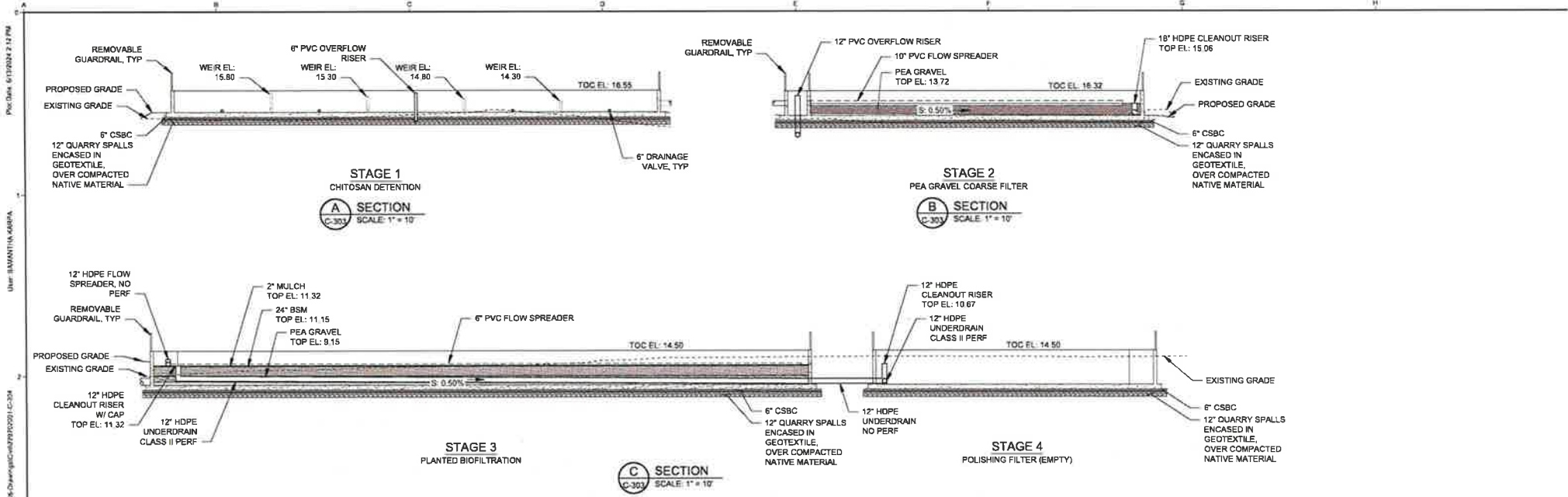

P:\Data_6/13/2024 2:12 PM
 User: SAMANTHA KARPA
 C:\Users\skarpa\OneDrive\Documents\CAD\CAD\2024\20240613\20240613_23070201\20240613_23070201\20240613_23070201.dwg
 Plot Date: 6/13/2024 2:12 PM

60% SUBMITTAL												SCALE	
PRELIMINARY DESIGN PHASE NOT FOR CONSTRUCTION												JOB NO 2287020 01	
THIS DOCUMENT IS AN INTERIM DOCUMENT AND NOT SUITABLE FOR CONSTRUCTION. AS AN INTERIM DOCUMENT, IT MAY CONTAIN DATA THAT IS POTENTIALLY INACCURATE OR INCOMPLETE AND IS NOT TO BE RELIED UPON WITHOUT THE EXPRESS WRITTEN CONSENT OF THE PREPARED.												DATE JUNE 2024	
NO	REVISION	DATE	BY	SCALES 0" = 1" 0" = 25mm IF THIS BAR IS NOT DIMENSION SHOWN, ADJUST SCALES ACCORDINGLY.		THIS PRELIMINARY DOCUMENT IS NOT FOR CONSTRUCTION. IT IS RELEASED UNDER THE AUTHORITY OF: SAMANTHA KARPA 2162595 JUNE 2024		DESIGNED SNK DRAWN CEC CHECKED SNK		PORT OF PORT TOWNSEND PORT TOWNSEND, WASHINGTON BOAT HAVEN MARINA STORMWATER IMPROVEMENTS PHASE 2 Kennedy Jenks		STORMWATER TREATMENT SECTIONS SHEET 31 OF 31 C-304	

File Path: 6/13/2024 4:05 AM
 User: SAMANTHA KARPA
 Project: 2297020 6/11/24 Design/10 00 Drawing/6/13/2024/02/01/C-501
 Path: \\pwr-01\shared\pwr\pwr\pwr\Documents\Drawings\PortTownsend\PortTownsendStormwaterImprovementsPhase2\2297020 6/11/24 Design/10 00 Drawing/6/13/2024/02/01/C-501

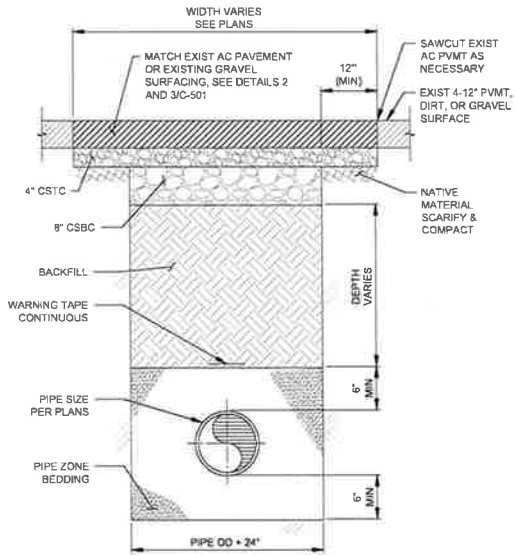

NOTE:
1. FINISHED GRADE TO MATCH EXISTING GRADE UNLESS OTHERWISE SHOWN.

1 PIPE TRENCH
SCALE: NTS

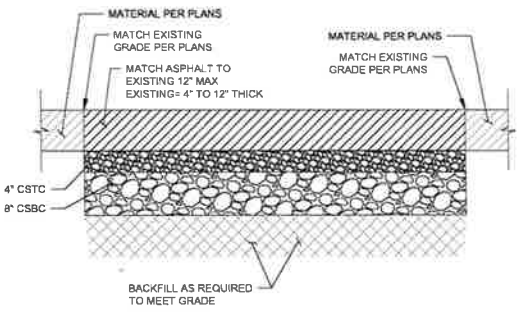

NOTE:
1. SEE PLANS FOR RESURFACING LIMITS.

2 ASPHALT PAVEMENT
SCALE: NTS

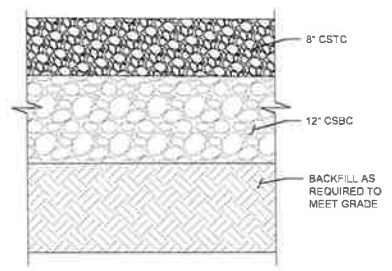

3 HEAVY DUTY GRAVEL SURFACING
SCALE: NTS

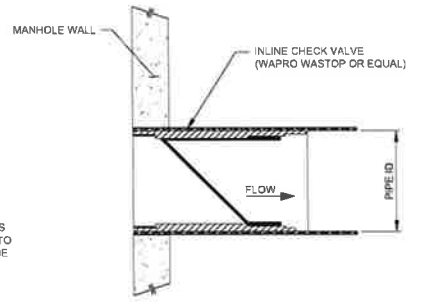

4 INLINE CHECK VALVE
SCALE: NTS

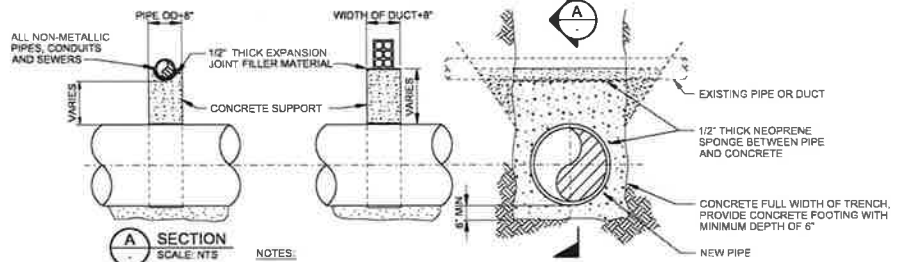

NOTES:
1. UNDERGROUND UTILITY SUPPORTS ARE TO BE PROVIDED WHEN MINIMUM CLEARANCE OF 12 INCHES CANNOT BE PROVIDED.
2. EXISTING PIPE OR DUCT SHALL BE SUPPORTED DURING INSTALLATION OF NEW PIPE AND SUPPORT.
3. BACKFILL TO BE BROUGHT UP UNIFORMLY ON BOTH SIDES OF CONC SUPPORT.

5 UNDERGROUND UTILITY SUPPORT
SCALE: NTS

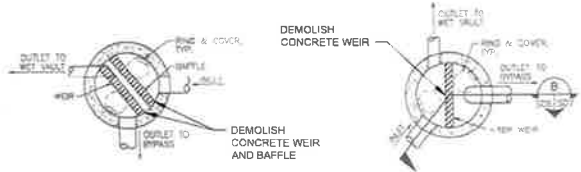

FLOW SPLITTER TYPE 1

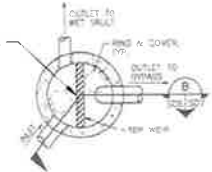

FLOW SPLITTER TYPE 2

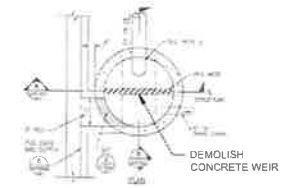

FLOW SPLITTER TYPE 3

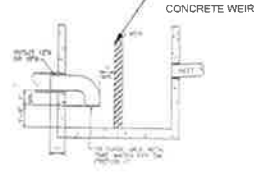
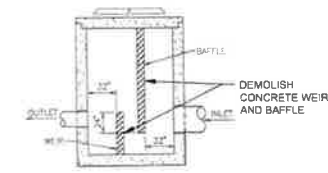

6 WEIR DEMOLITION
SCALE: NTS

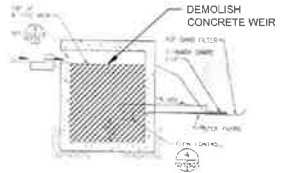

60% SUBMITTAL PRELIMINARY DESIGN PHASE NOT FOR CONSTRUCTION THIS DOCUMENT IS AN INTERIM DOCUMENT AND NOT SUITABLE FOR CONSTRUCTION. AS AN INTERIM DOCUMENT, IT MAY CONTAIN DATA THAT IS POTENTIALLY INACCURATE OR INCOMPLETE AND IS NOT TO BE RELIED UPON WITHOUT THE EXPRESS WRITTEN CONSENT OF THE PREPARED.	SCALES 0" = 1" 0 = 25mm IF THIS BAR IS NOT DIMENSION SHOWN, ADJUST SCALES ACCORDINGLY.				DESIGNED: SNK DRAWN: CEC CHECKED: SNK	PORT OF PORT TOWNSEND PORT TOWNSEND, WASHINGTON BOAT HAVEN MARINA STORMWATER IMPROVEMENTS PHASE 2	CIVIL DETAILS - I	SCALE: NTS JOB NO: 2287020 01 DATE: JUNE 2024 SHEET 27 OF 27 C-501
	NO. REVISION DATE BY							

DESIGN CRITERIA

ACI 318.14, IBC 2021, ASCE 7.16

GENERAL CONDITIONS

- THE CONTRACTOR SHALL VERIFY AND REVIEW ALL ITEMS WITHIN THE DRAWINGS PRIOR TO PROCEEDING WITH THE WORK. NOTIFY THE ENGINEER IMMEDIATELY WITH ANY DISCREPANCIES.
- IF A SPECIFIC DETAIL IS NOT SHOWN FOR ANY PART OF THE WORK, THE CONSTRUCTION SHALL BE THE SAME AS FOR SIMILAR WORK.
- DIMENSIONS ARE NOT TO BE SCALED FROM THE PLANS. SECTIONS OR DETAILS WITHIN THE DRAWINGS.
- THE CONTRACTOR SHALL BE SOLELY RESPONSIBLE FOR THE CONSTRUCTION MEANS, METHODS, TECHNIQUES, SEQUENCE AND PROCEDURES.
- ALL WORK SHALL CONFORM TO THE MINIMUM STANDARDS OF THE REFERENCED BUILDING AND ALL OTHER REGULATING AGENCIES EXERCISING AUTHORITY OVER ANY PORTION OF THE WORK.
- SPECIFIC NOTES AND DETAILS IN THE DRAWINGS SHALL TAKE PRECEDENCE OVER GENERAL NOTES AND SPECIFICATIONS.
- NOTIFY THE ENGINEER OF ALL CHANGES MADE IN THE FIELD PRIOR TO INSTALLATION.

TANK FOUNDATION

- FOUNDATION DESIGN PARAMETERS PER AISC, INC. RECOMMENDATIONS
 - A. WIND W. BE CLASSIFICATION
 - B. FOOTING BEARING PRESSURE: 3,500 PSF
- C. LATERAL EARTH PRESSURE
 - STATIC AT REST (ABOVE WATER): 30 PCF
 - STATIC AT REST (BELOW WATER): 30 PCF
 - SEISMIC AT REST: 1.34 PCF
 - STATIC PASSIVE (ABOVE WATER): 300 PCF
 - STATIC PASSIVE (BELOW WATER): 150 PCF
 - SEISMIC PASSIVE: 17.34 PCF
 - COEFFICIENT OF FRICTION: 0.3
- SURFACE PREPARATION, DRAINAGE PROVISIONS AND OTHER RELEVANT SOIL CONSIDERATIONS ARE TO BE IN ACCORDANCE WITH THE GEOTECHNICAL REPORT.

STRUCTURAL STEEL WELDING

- CONFORM TO THE AISC CODES D1.1 AND D1.2. USE ONLY STATE CERTIFIED WELDERS.
- USE DRY PIT ELECTRODES.
- WELDS ARE TO BE 1/8" INCH CONTINUOUS FILLET WELDS UNLESS NOTED OTHERWISE IN THE DRAWINGS.

STRUCTURAL STEEL

- REFERENCE STANDARDS (LATEST EDITION OF THE AISC CODE OF "STANDARD PRACTICE FOR STEEL BUILDINGS AND BRIDGES")
- MATERIALS
 - BOLTS: STEEL TO WOOD - ASTM A307; STEEL TO STEEL - ASTM A325; STEEL TO CONCRETE - HEAVY HEX HEAD ASTM F1554 GR. 36; WOOD TO CONCRETE - ASTM F1648 GR. 36; W/ANG + SHAPES - ASTM A36; TUBES - ASTM A500, GRADE B (P_y = 48,000 PSI); ALL OTHER STEEL - ASTM A36 (P_y = 36,000 PSI)

REINFORCING STEEL

- REFERENCE STANDARDS: ACI DETAIL MANUAL AND CRSI MANUAL OF STANDARD PRACTICE
- MATERIALS
 - A. REINFORCING STEEL: ASTM A631, GRADE RE. UNGRADED
- LAP CONTINUOUS REINFORCING BARS OR BARS DIAMETER, UNLESS NOTED OTHERWISE. PROVIDE CORNER BARS FOR ALL HORIZONTAL REINFORCEMENT. PROVIDE CORNER BARS OR HOOK BARS (90 OR 180 DEGREE) AT THE END OF ALL HORIZONTAL REINFORCEMENT IN WALLS. A615 STEEL IS NOT TO BE WELDED TO OTHER STEEL MEMBERS.
- REINFORCEMENT COVER
 - FOOTINGS: 3 INCHES TO EARTH; 2 INCHES TO FORMED SURFACE
 - SLABS: 2 INCHES TO EARTH
- FORMED SURFACE
 - EXTERIOR FACE: 1/2 INCHES, #5 BAR AND SMALLER; 2 INCHES, #6 BAR AND LARGER
 - INTERIOR FACE: 1/2 INCHES FOR SLABS AND WALLS; 1/2 INCHES FOR BEAMS AND COLUMNS
- REINFORCING STEEL: BARS MAY NOT BE WELDED TO OTHER STEEL ELEMENTS (ACI 3.3.2)
- REBAR SHALL BE LAPPED PER THE LAP SPLICE LENGTH SCHEDULE BELOW FOR EACH CONCRETE ELEMENT:

BAR SIZE	WALL/COLUMN	FOOTINGS SOG	FOOTING DOWN EMBEDMENT (END PER PLAN)
#4	30"	30"	8"
#5	30"	30"	12"
#6	48"	48"	14"
#7	66"	66"	16"
#8	78"	78"	18"

CONCRETE

- REFERENCE STANDARDS: ACI 301 AND ACI 318
- MINIMUM CONCRETE STRENGTH AT 28 DAYS: 3,500 PSI
- THE WATER/CEMENT RATIO SHALL NOT EXCEED 0.45 (BY WEIGHT)
- AGGREGATE GRADING SHALL COMPLY WITH ASTM #57 GRADATION OR BETTER. PORTLAND CEMENT SHALL CONFORM TO ASTM 1-D1E, TYPE I.
- COMPLY WITH ACI 301 FOR MIXING. DO NOT EXCEED THE AMOUNT OF WATER SPECIFIED IN THE APPROVED MIX PROPORTIONS OF AGGREGATE TO CEMENT SHALL BE SUCH AS TO PRODUCE A DENSE WORKABLE MIX WHICH CAN BE PLACED WITHOUT SEGREGATION OR EXCESSIVE FREE SURFACE WATER.
- COMPLY WITH ACI 301 FOR PLACEMENT. PROVIDE A 1/8" INCH CHAMFER AT ALL EXPOSED CONCRETE EDGES, UNLESS INDICATED OTHERWISE IN THE DRAWINGS.
- MAXIMUM SLUMP TO BE 4" ± 1". DO NOT ADD WATER TO THE MIX TO INCREASE SLUMP. GREATER SLUMP, ACCELERATED SET OR HIGH EARLY STRENGTH MAY BE ACHIEVED BY USING APPROVED ADMIXTURES.
- COMPLY WITH ACI 305R FOR PLACEMENT IN HOT WEATHER AND ACI 306R FOR PLACEMENT IN COLD WEATHER.
- PROVIDE AIR-ENTRAINMENT OF 5.12% ± 1.12% FOR ALL CONCRETE

PREMOLDED JOINT FILLER

- PREMOLDED JOINT FILLER FOR USE IN EXPANSION (THROUGH) JOINTS SHALL CONFORM TO EITHER AASHTO M213 SPECIFICATIONS FOR "PREFORMED EXPANSION JOINT FILLERS FOR CONCRETE PAVING AND STRUCTURAL CONSTRUCTION" EXCEPT THAT THE REQUIREMENT FOR WATER ABSORPTION IS DELETED, OR ASTM F1774 SPECIFICATIONS FOR "PRE-CURED CLOSED-CELL POLYURETHAN EXPANSION JOINT FILLERS FOR CONCRETE PAVING AND STRUCTURAL CONSTRUCTION".

WATERSTOP

- WATERSTOPS SHALL BE FLEXIBLE POLYVINYL CHLORIDE (PVC) EXTRUDED FROM AN UNFIBERED MATERIAL. THE PVC COMPOUND SHALL NOT CONTAIN ANY SCRAPPED OR RECLAIMED MATERIALS OR FILLERS.
- FIELD BUTT SPLICES SHALL BE FUSE WELDED USING A HEAT SEALING METHOD IN ACCORDANCE WITH MANUFACTURER INSTRUCTIONS. LAPPING, GLUING, OR USE OF ADHESIVES SHALL NOT BE PERMITTED.
- CENTER WATERSTOP IN THE JOINT AND SECURE WATERSTOP IN THE CORRECT POSITION USING HOOD BUSHES, DOWNSCREWS, OR EYEBOLTS SPACED AT 12" ON CENTER ALONG THE LENGTH OF THE PVC WATERSTOP AND WIRE TIED TO THE REINFORCING STEEL.

SHOP DRAWINGS AND SUBMITTALS

- SUBMIT 3 COPIES OF LAYOUT DRAWINGS FOR REVIEW OF A. REINFORCING STEEL
- SUBMIT 3 COPIES OF SPECIFICATIONS FOR REVIEW OF: A. CONCRETE DESIGN MIX; B. WATERSTOPS
- QUALITY CONTROL PLAN

SPECIAL INSPECTIONS

- SPECIAL INSPECTIONS ARE TO BE PERFORMED BY INDEPENDENT, SUPERVISORALLY APPROVED AND NOT IN ACCORDANCE WITH IBC SECTION 1701.2 AND PROVIDE THE DUTIES AND RESPONSIBILITIES AS INDICATED IN SECTION 1701.3
- A CERTIFICATE OF SATISFACTORY COMPLETION OF WORK REQUIRING SPECIAL INSPECTION MUST BE COMPLETED AND SUBMITTED TO THE BUILDING OFFICIAL UPON COMPLETION OF PROJECT
- SPECIAL INSPECTION IS NOT A SUBSTITUTE FOR INSPECTION BY A JURISDICTIONAL INSPECTOR.
- THE SPECIAL INSPECTIONS REQUIRED FOR THIS PROJECT ARE AS NOTED IN THE SUMMARY OF SPECIAL INSPECTION.

JOB SITE SAFETY

THE ENGINEER HAS NOT BEEN RETAINED OR COMPENSATED TO PROVIDE DESIGN AND/OR CONSTRUCTION REVIEW SERVICES RELATED TO THE CONTRACTOR'S SAFETY PRECAUTIONS OR TO MEANS, METHODS, TECHNIQUES OR PROCEDURES FOR THE CONTRACTOR TO PERFORM THE WORK. THE UNDERTAKING OF PERIODIC SITE VISITS BY THE ENGINEER SHALL NOT BE CONSTRUED AS SUPERVISION OF ACTUAL CONSTRUCTION. NOR MAKE HIM RESPONSIBLE FOR PROVIDING A SAFE PLACE FOR THE PERFORMANCE OF THE WORK BY THE CONTRACTOR, SUB-CONTRACTOR OR ANY PERSON ON THE SITE.

SUMMARY OF SPECIAL INSPECTION

ITEM	INSPECTION REQUIRED	REFERENCE
GRADING AND EXCAVATION	VERIFY EXCAVATION TO PROPER DEPTH. PERIODIC INSPECTION	REFER TO GEOTECHNICAL MEMO
	VERIFY USE OF PROPER MATERIALS, DENSITIES AND LIFT THICKNESS DURING PLACEMENT AND COMPACTION OF FILL. CONTINUOUS INSPECTION	
CONCRETE	VERIFY MIX DESIGN SUPPLIED MEETS APPROVED MIX DESIGN. PERIODIC INSPECTION	REFER TO STAMPED MIX DESIGN BY OGC
	PLACEMENT OF CONCRETE. INCLUDES VERIFYING SLUMP AND AIR CONTENT TESTS. CONTINUOUS INSPECTION	REFER TO DRAWINGS; NOT REQUIRED FOR SITE-WORK CONCRETE
	PERFORM CYLINDER STRENGTH TESTS	FOUNDATION WALLS/SLAB - 3000 PSI
REINFORCING STEEL	VERIFY PLACEMENT, COVER AND BAR SIZE. PERIODIC INSPECTION	REFER TO DRAWINGS
	VERIFY GRADE. PERIODIC INSPECTION	ASTM A631, GRADE #2
STRUCTURAL STEEL	VERIFY MEMBER SIZE AND PLACEMENT, AND BOLTED CONNECTIONS ARE SNUG TIGHT. PERIODIC INSPECTION	REFER TO DRAWINGS
	ON-SITE WELDING	PERIODIC INSPECTION OF FILLET WELDS 1/4" AND LESS
EPOXY OR MECHANICAL ANCHORS	VERIFY INSTALLATION SIZE AND DEPTH. CONTINUOUS INSPECTION	REFER TO DRAWINGS OR FIELD DIRECTIVES
WATERSTOP	VERIFY PLACEMENT, BUTT SPLICES, FITTINGS. PERIODIC INSPECTION	REFER TO DRAWINGS AND MANUFACTURER'S INSTALLATION INSTRUCTIONS

ABBREVIATIONS

B	DIAMETER
BTM	BOTTOM
CLR	CLEAR
CONC	CONCRETE
CTRL	CONTROL
CS	COUNTERSINK
EA	EACH
EX	EXISTING
FLH	FLAT HEAD
FNDR	FOUNDATION
FTG	FOOTING
H	HORIZONTAL
HN	HEX HEAD
HFL	HIGH FLOW LINE
MLW	MEAN LOWER LOW WATER
NOAA	NATIONAL OCEANIC AND ATMOSPHERIC ADMINISTRATION
O.C.	ON CENTER
PROP	PROPOSED
REQD	REQUIRED
RT	RECTANGULAR ALUMINUM SECTION
SS	STAINLESS STEEL
TOP	TOP
T	THICK
TECC	TEMPORARY EROSION CONTROL
TRANS	TRANSVERSE
TYP	TYPICAL
UHMW	ULTRA-HIGH MOLECULAR WEIGHT POLYETHYLENE
V	VERTICAL
VF	VERIFY IN FIELD
WI	WITH

60% SUBMITTAL



DESIGNED: DT
 DRAWN: IK
 CHECKED: JS

PORT OF PORT TOWNSEND
 PORT TOWNSEND, WASHINGTON
 BOAT HAVEN MARINA
 STORMWATER IMPROVEMENTS PHASE 2

Kennedy Jenks FACET

PROJECT NO. 2021-001
 DATE: 06/20/24
 SCALE: N/A

STRUCTURAL GENERAL NOTES

PRELIMINARY DESIGN PHASE
 NOT FOR CONSTRUCTION
 THIS DOCUMENT IS AN INTERIM DOCUMENT AND NOT SUITABLE FOR CONSTRUCTION AS AN INTERIM DOCUMENT. IT MAY CONTAIN DATA THAT IS POTENTIALLY INACCURATE OR INCOMPLETE AND IS NOT TO BE RELIED UPON WITHOUT THE EXPRESS WRITTEN CONSENT OF THE PREPARER.

NO.	REVISION	DATE	BY

SCALE	N/A
JOB NO.	2207200-01
DATE	JUNE 2024
SHEET OF	S-001

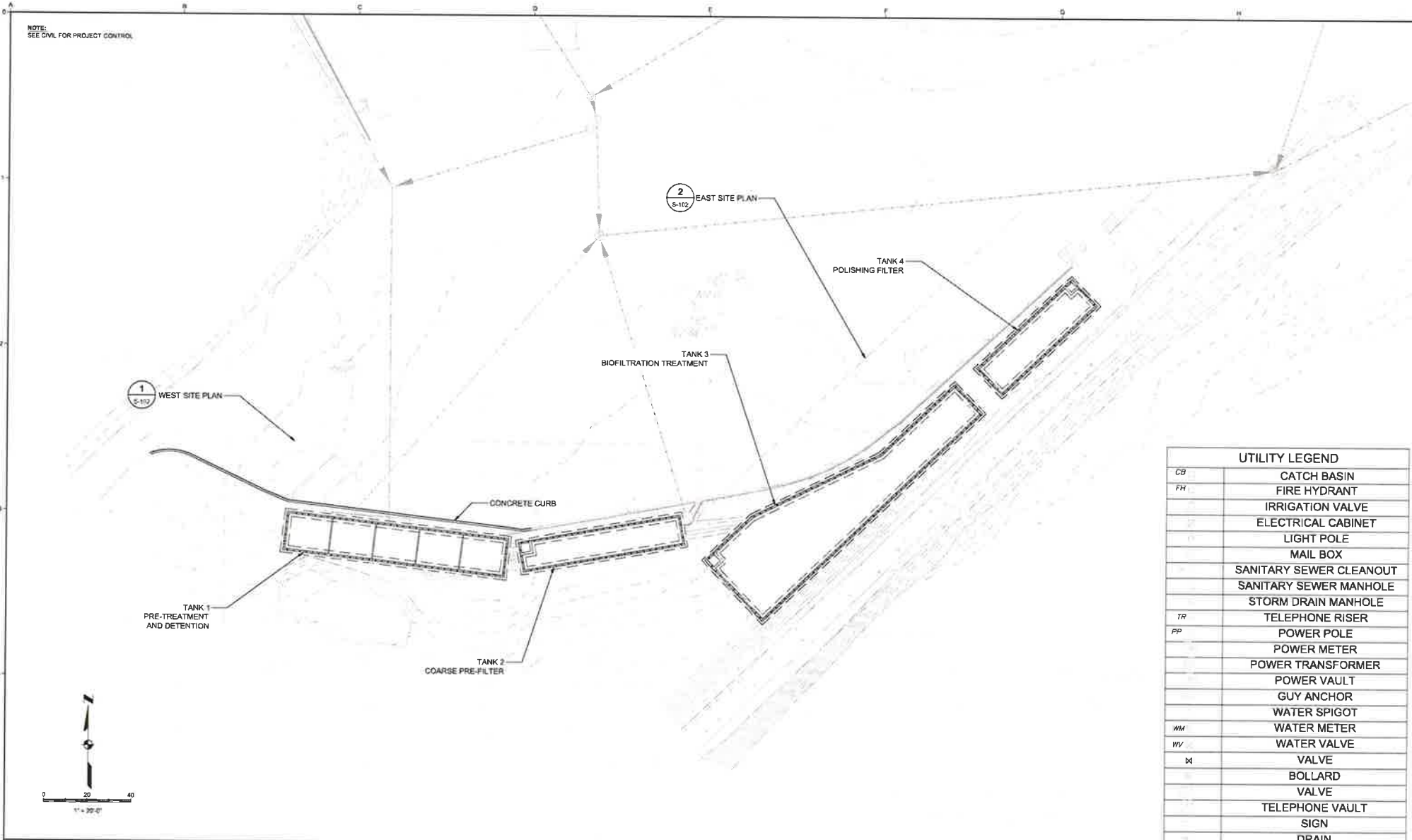

60 % SUBMITTAL

PRELIMINARY DESIGN PHASE
NOT FOR CONSTRUCTION
THIS DOCUMENT IS AN INTERIM DOCUMENT AND NOT SUITABLE FOR
CONSTRUCTION AS AN INTERIM DOCUMENT. IT MAY CONTAIN DATA THAT
IS POTENTIALLY INACCURATE OR INCOMPLETE AND IS NOT TO BE RELIED
UPON WITHOUT THE EXPRESS WRITTEN CONSENT OF THE PREPARER.

NO	REVISION	DATE	BY

SCALES
0" = 1'
0" = 25mm
IF THIS BAR IS NOT
DIMENSION SHOWN,
ADJUST SCALES
ACCORDINGLY.

DESIGNED	OT
DRAWN	K
CHECKED	JS

PORT OF PORT TOWNSEND
PORT TOWNSEND, WASHINGTON
BOAT HAVEN MARINA
STORMWATER IMPROVEMENTS PHASE 2

K Kennedy Jenks **FACET**

8750 4th Ave NE, Suite 377
Seattle, WA 98117
Tel: 206.252.2222
www.kjcm.com

**STRUCTURAL
KEY MAP**

SCALE 1" = 30'

JOB NO 2297520-01
DATE JUNE 2024
SHEET 01 OF 10
S-101

NOTE:
SEE CIVIL FOR PROJECT CONTROL

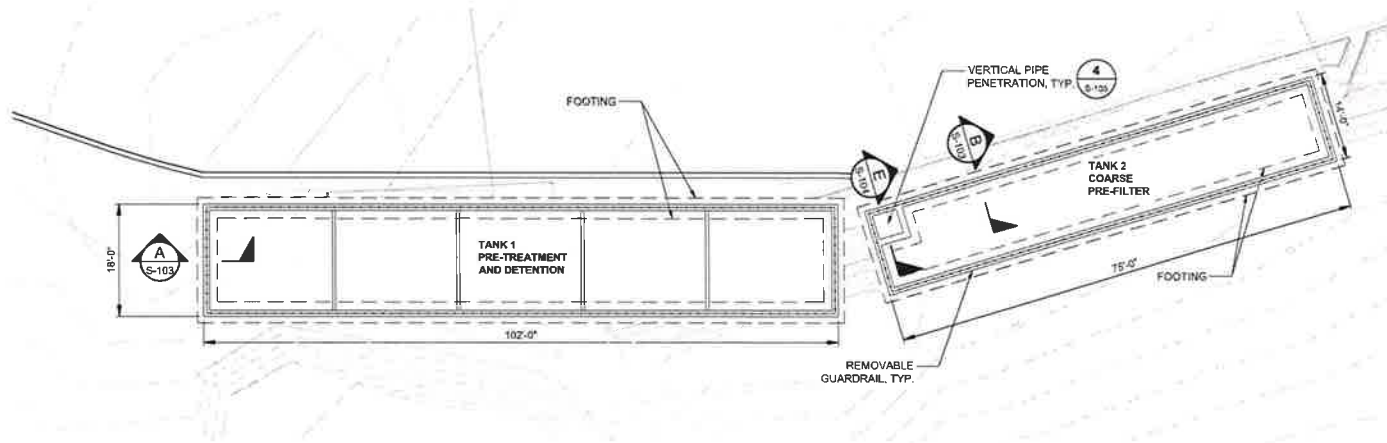

1 WEST SITE PLAN
SCALE: 1" = 10'

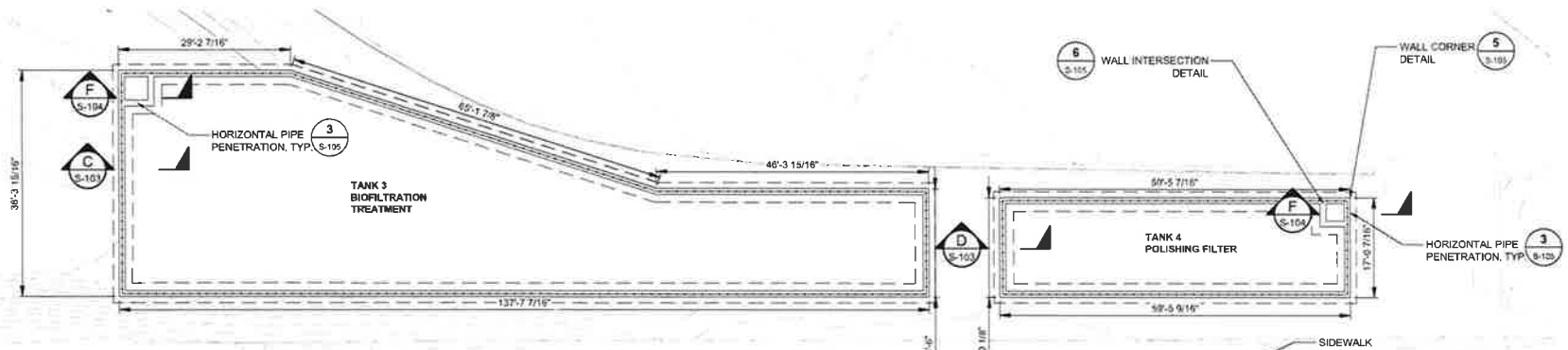

2 EAST SITE PLAN
SCALE: 1" = 10'

60 % SUBMITTAL

PRELIMINARY DESIGN PHASE
NOT FOR CONSTRUCTION
THIS DOCUMENT IS AN INTERIM DOCUMENT AND NOT SUITABLE FOR
CONSTRUCTION AS AN INTERIM DOCUMENT. IT MAY CONTAIN DATA THAT
IS POTENTIALLY INACCURATE OR INCOMPLETE AND IS NOT TO BE RELIED
UPON WITHOUT THE EXPRESS WRITTEN CONSENT OF THE PREPARER.

NO.	REVISION	DATE	BY

SCALES
1" = 10'
IF THIS BAR IS NOT
DIMENSION SHOWN,
ADJUST SCALES
ACCORDINGLY.

DESIGNED	DT
DRAWN	JK
CHECKED	JK
	JS

PORT OF PORT TOWNSEND
PORT TOWNSEND, WASHINGTON
BOAT HAVEN MARINA
STORMWATER IMPROVEMENTS PHASE 2



1000 4th Ave SE, Suite 102
Tacoma, WA 98402
Tel: 253.302.2224
www.kennedyjenks.com

STRUCTURAL
SITE MAP

SCALE	1" = 10'
JOB NO	22R1020.01
DATE	JUNE 2024
SHEET	01
	S-102

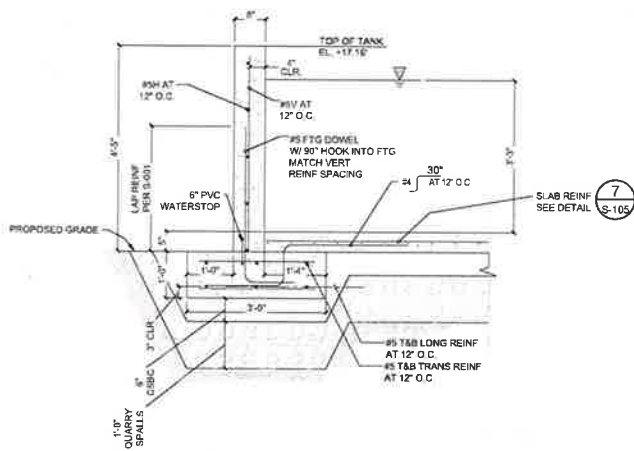

TANK 1 SECTION A
S-003

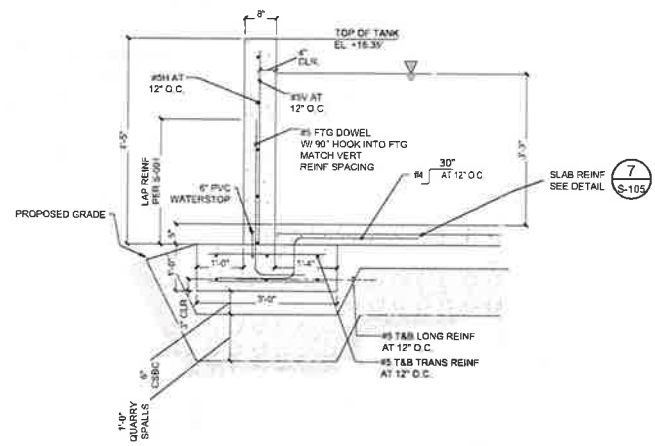

TANK 2 SECTION B
S-003

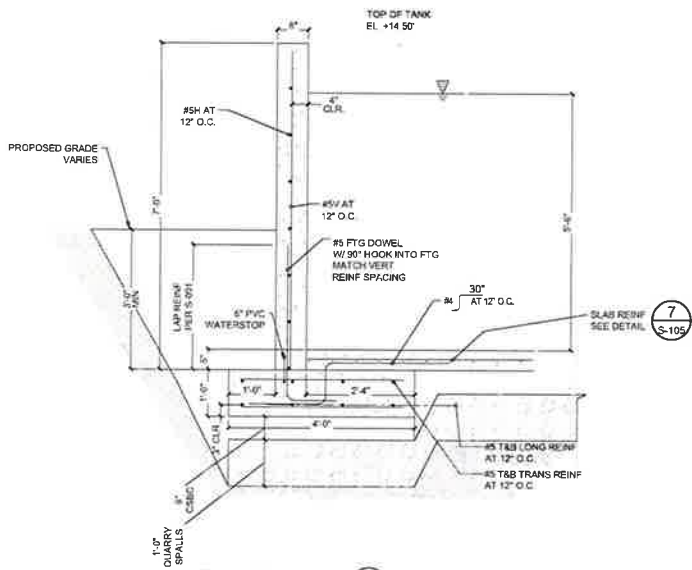

TANK 3 SECTION C
S-003

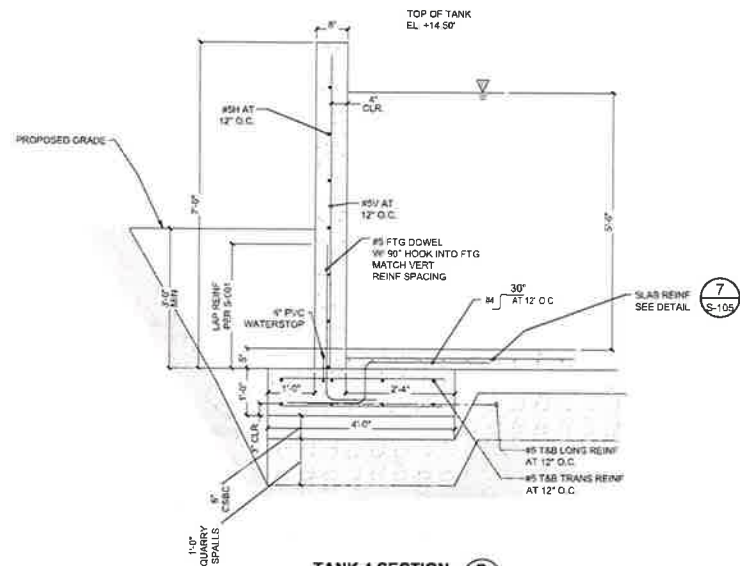

TANK 4 SECTION D
S-003

60 % SUBMITTAL

PRELIMINARY DESIGN PHASE
NOT FOR CONSTRUCTION
THIS DOCUMENT IS AN INTERIM DOCUMENT AND NOT SUITABLE FOR
CONSTRUCTION AS AN INTERIM DOCUMENT. IT MAY CONTAIN DATA THAT
IS POTENTIALLY INACCURATE OR INCOMPLETE AND IS NOT TO BE RELIED
UPON WITHOUT THE EXPRESS WRITTEN CONSENT OF THE PREPARER

NO	REVISION	DATE	BY

SCALES
0" = 1'
0" = 25mm
IF THIS BAR IS NOT
DIMENSION SHOWN,
ADJUST SCALES
ACCORDINGLY.

DESIGNED
DT
DRAWN
IK
CHECKED
JS

PORT OF PORT TOWNSEND
PORT TOWNSEND, WASHINGTON
BOAT HAVEN MARINA
STORMWATER IMPROVEMENTS PHASE 2

K Kennedy Jenks **FACET**

1384 4th Ave SE, Suite 300
Burien, WA 98148
P: 206.833.8221
F: 206.833.8222
www.kjfacet.com

STORMWATER TREATMENT
FACILITY SECTIONS

SCALE 1" = 12"
JOB NO. 2257020 D1
DATE JUNE 2024
SHEET 07
S-103

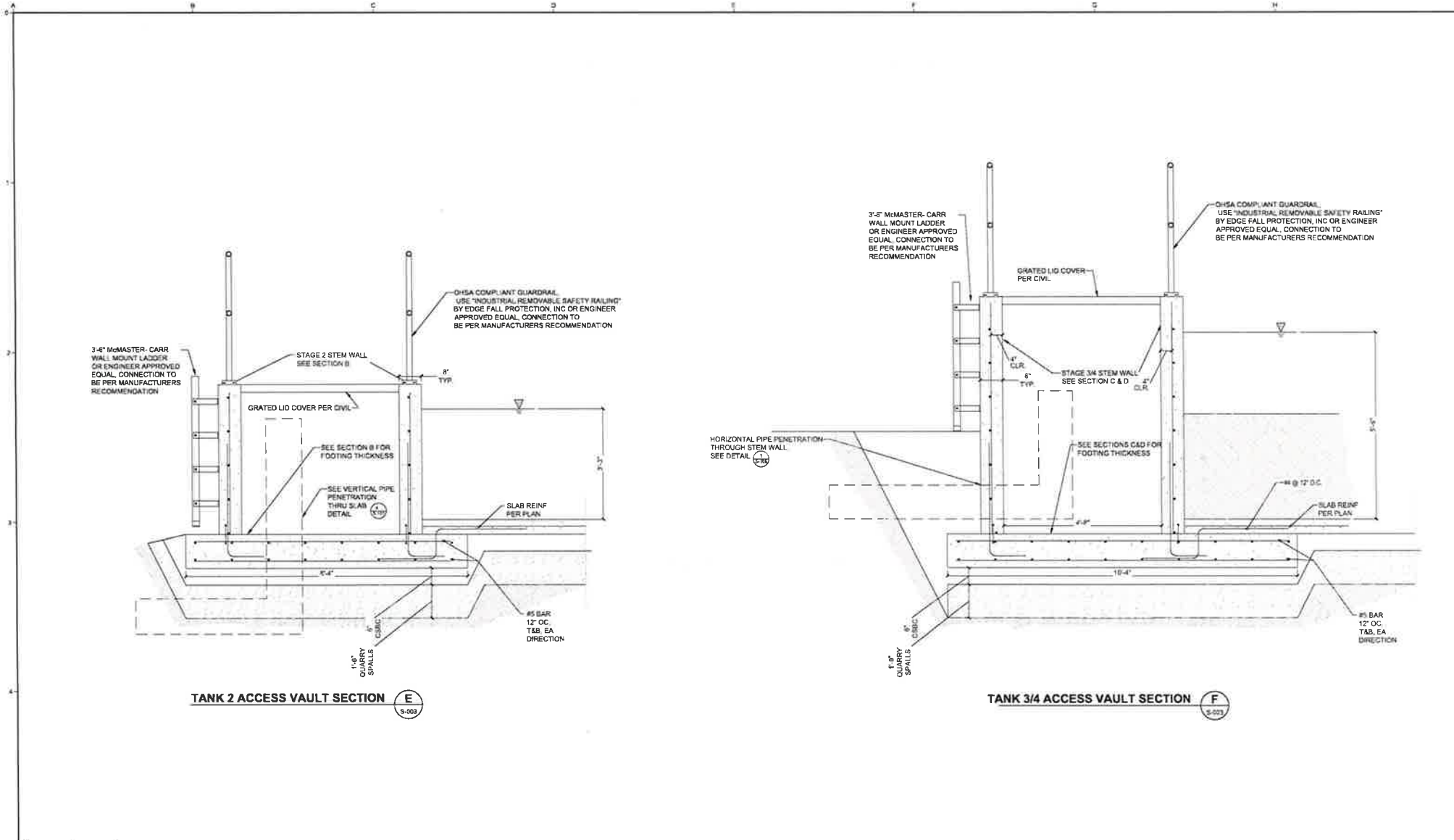

TANK 2 ACCESS VAULT SECTION E
S-003

TANK 3/4 ACCESS VAULT SECTION F
S-003

60 % SUBMITTAL

PRELIMINARY DESIGN PHASE
NOT FOR CONSTRUCTION
THIS DOCUMENT IS AN INTERIM DOCUMENT AND NOT SUITABLE FOR
CONSTRUCTION AS AN INTERIM DOCUMENT. IT MAY CONTAIN DATA THAT
IS POTENTIALLY INACCURATE OR INCOMPLETE AND IS NOT TO BE RELIED
UPON WITHOUT THE EXPRESS WRITTEN CONSENT OF THE PREPARER.

NO	REVISION	DATE	BY

SCALES
1" = 1'
0 25mm
IF THIS BAR IS NOT
DIMENSION SHOWN,
ADJUST SCALES
ACCORDINGLY.

DESIGNED	DT
DRAWN	IK
CHECKED	JS

PORT OF PORT TOWNSEND
PORT TOWNSEND, WASHINGTON
BOAT HAVEN MARINA
STORMWATER IMPROVEMENTS PHASE 2

K Kennedy Jenks **FACET**

8720 4th St, Suite 202
Seattle, WA 98112
PH: 206.461.2222
WWW.KJENKYS.COM

STORMWATER TREATMENT
FACILITY SECTIONS

SCALE	1" = 1'
JOB NO	2257020 01
DATE	JUNE 2024
SHEET OF	S-104

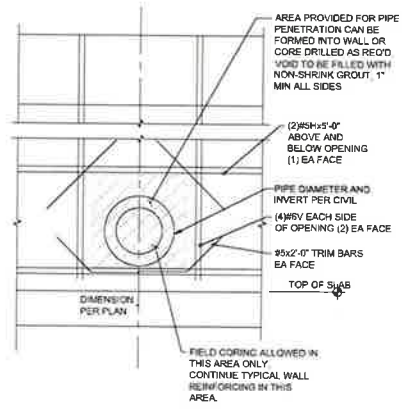

HORIZONTAL PIPE - WALL PENETRATION 3
S-102

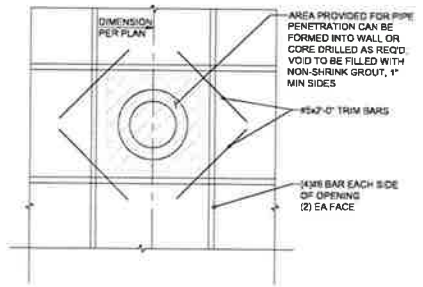

VERTICAL PIPE - FOOTING/SLAB PENETRATION 4
S-104

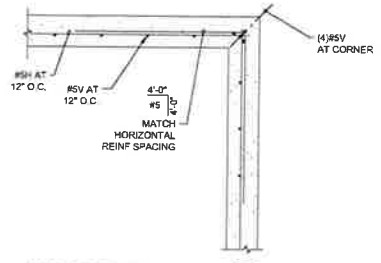

WALL CORNER DETAIL 5
S-105

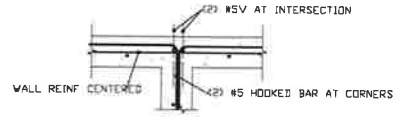

WALL INTERSECTION DETAIL 6
S-102

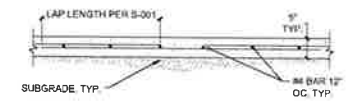

SLAB DETAIL 7
S-103

60 % SUBMITTAL

PRELIMINARY DESIGN PHASE
NOT FOR CONSTRUCTION
THIS DOCUMENT IS AN INTERIM DOCUMENT AND NOT SUITABLE FOR CONSTRUCTION. AS AN INTERIM DOCUMENT, IT MAY CONTAIN DATA THAT IS POTENTIALLY INACCURATE OR INCOMPLETE AND IS NOT TO BE RELIED UPON WITHOUT THE EXPRESS WRITTEN CONSENT OF THE PREPARED.

NO.	REVISION	DATE	BY

SCALES
0 1" = 1"
0 25mm
IF THIS BAR IS NOT DIMENSION SHOWN, ADJUST SCALES ACCORDINGLY.

DESIGNED
DT
DRAWN
JK
CHECKED
JS

PORT OF PORT TOWNSEND
PORT TOWNSEND, WASHINGTON
BOAT HAVEN MARINA
STORMWATER IMPROVEMENTS PHASE 2

Kennedy Jenks FACET

8750 N. Ave 10, Suite 101
Denver, CO 80231
Tel: 303.733.8200
www.kjfacet.com

STORMWATER TREATMENT
FACILITY DETAILS

SCALE 1" = 1"
JOB NO. 2297020 01
DATE JUNE 2024
SHEET 01
S-105

INSTRUMENT CALLOUTS AND TAG SCHEMA

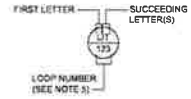

TYPICAL TAG FORMAT
 LT 123 INSTRUMENT TAG NUMBER
 L T SUCCEEDING LETTER(S)
 123 LOOP NUMBER

EXPANDED TAG FORMAT
 2001-123A INSTRUMENT TAG NUMBER
 LT 123 AREA NUMBER
 L T SUCCEEDING LETTER(S)
 123 LOOP NUMBER
 A OPTIONAL SUFFIX

FIRST LETTER (1)	MODIFIER	READOUT OR PASSIVE FUNCTION	OUTPUT FUNCTION	MODIFIER
A		ALARM	USER'S CHOICE (16)	USER'S CHOICE (21)
B		USER'S CHOICE (2)	USER'S CHOICE (16)	USER'S CHOICE (21)
C		USER'S CHOICE (3a)(5)	CONTROL (23a)(23c)	CLOSED (27b)
D		DENSITY	DAMPER	
E		VOLTAGE (2)	SENSOR (PRIMARY ELEMENT)	
F		FLOW, FLOW RATE (2)	RATIO (FRACTION) (2b)	
G		USER'S CHOICE	GLASS VIEWING DEVICE (16)	
H		HAND (2)		HIGH (27a)(28a)(2)
I		CURRENT (ELECTRICAL)(2)	INDICATE (17)	
J		POWER (2)	SCAN (18)	
K		TIME, TIME SCHEDULE (2)	TIME RATE OF CHANGE (12)(13)	CONTROL STATION (24)
L		LEVEL (2)	LIGHT (19)	LOW (27c)(28)(2)
M		MOISTURE	MOMENTARY	MIDDLE, INTERMEDIATE
N		USER'S CHOICE (5)	USER'S CHOICE (5)	USER'S CHOICE (5)
O		USER'S CHOICE (5)	OFFICE, RESTRICTION	OPEN (27a)
P		PRESSURE, VACUUM (2)	POINT (TEST) CONNECTION	
Q		QUANTITY (2)	INTEGRATE, TOTALIZE	
R		RADIATION (2)	RECORD (22)	RUN
S		SPEED, FREQUENCY (2)	SAFETY (14)	STOP
T		TEMPERATURE (2)		TRANSMIT
U		MULTI VARIABLE (27)(1)	MULTIFUNCTION (21)	MULTIFUNCTION (21)
V		VIBRATION, MECHANICAL ANALYSIS (23a)(2)	MULTIFUNCTION (21)	MULTIFUNCTION (21)
W		WEIGHT, FORCE (2)	WELL, PROBE	
X		UNCLASSIFIED (8)	X AXIS (11c)	UNCLASSIFIED (8)
Y		EVENT, STATE, PRESENCE (2)(2)	Y AXIS (11c)	UNCLASSIFIED (8)
Z		POSITION, DIMENSION (2)	Z AXIS (11c) SAFETY INSTRUMENTED SYSTEM (30)	UNCLASSIFIED (8)

NOTE: NUMBERS IN PARENTHESES REFER TO EXPLANATORY NOTES IN ANSI/ISA-5.1-2009, SECTION # 2

	LOCATED IN FIELD VISIBLE AT LOCATION OPERATOR ACCESSIBLE	LOCATED ON MAIN PANEL VISIBLE ON PANEL FRONT OPERATOR ACCESSIBLE	LOCATED IN MAIN PANEL CABINET NOT VISIBLE ON PANEL FRONT NOT OPERATOR ACCESSIBLE	LOCATED ON SECONDARY PANEL VISIBLE ON PANEL FRONT OPERATOR ACCESSIBLE	LOCATED IN SECONDARY PANEL CABINET NOT VISIBLE ON PANEL FRONT NOT OPERATOR ACCESSIBLE
SHARED DISPLAY SHARED CONTROL					
PROGRAMMABLE LOGIC CONTROL					
COMPUTER FUNCTION					
INSTRUMENT					
PILOT LIGHT					

LETTER MAPPING
 A IDENTIFICATION LETTERS (SEE TABLE OR REFER TO ANSI/ISA-5.1-2009, TABLE 4.1)
 B LOOP NUMBER
 C USER DESCRIPTION/FUNCTION DESIGNATION (SEE LIST THIS SHEET)
 D MEASUREMENT (REFER TO ANSI/ISA-5.1-2009, TABLE 5.2.2)
 E PROCESS CONTROL, DESCRIPTOR LINE 1
 F PROCESS CONTROL, DESCRIPTOR LINE 2
 G PROCESS CONTROL, DESCRIPTOR LINE 3

DISPLAY AND CONTROL SYMBOLS FOR ANALOG MEASURED VARIABLES MAY ALSO INDICATE THE PRESENCE OF DERIVED SETPOINTS USED FOR ALARM GENERATION

PLC I/O

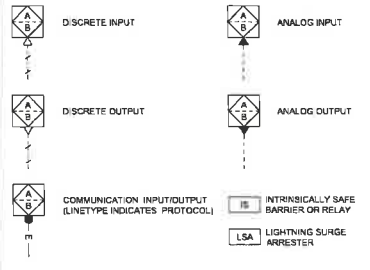

MISCELLANEOUS

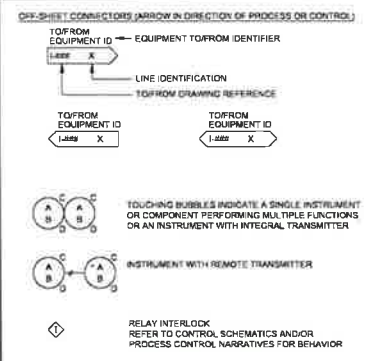

FUNCTION DESIGNATIONS

SWITCHES	ANALYTICAL INSTRUMENTS
AM AUTO-MANUAL	ALK ALKALINITY
ESTOP EMERGENCY STOP	CL2 CHLORINE CONCENTRATION
F-R FORWARD REVERSE	CO CARBON MONOXIDE
H-OA HAND-OFF-AUTO	CO2 CARBON DIOXIDE
LOR LOCAL-REMOTE	COMB COMBUSTIBLE GAS
LOR LOCAL-OFF-REMOTE	COND CONDUCTIVITY
O-C OPEN-CLOSE	COMB COMBUSTIBLE GAS
O-C OPEN-CLOSE-AUTO	DO DISSOLVED OXYGEN
O-O ON-OFF	H2S HYDROGEN SULFIDE
DSC OPEN STOP, D.OSE	HUM HUMIDITY
POT POTENTIOMETER	NO3 NITRATE
RST RESET	O2 OXYGEN CONCENTRATION
S-S START-STOP	O3 OZONE
	ORP OXIDATION REDUCTION POTENTIAL
	PH PHENOL CONCENTRATION
	SO2 SULFUR DIOXIDE
	TH TOTAL HARDNESS
	TURB TURBIDITY
	UV ULTRAVIOLET TRANSMITTANCE OR INTENSITY
	NOTED AS TOTAL OR FREE

INSTRUMENT AND EQUIPMENT SERVICES



LINE SYMBOLLOGY

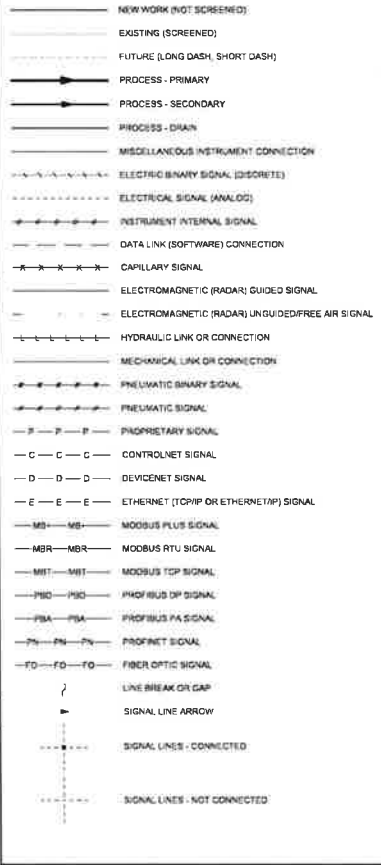

SIGNAL PROCESSING FUNCTIONS

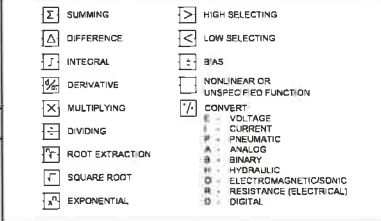

TYPICAL CONNECTIONS

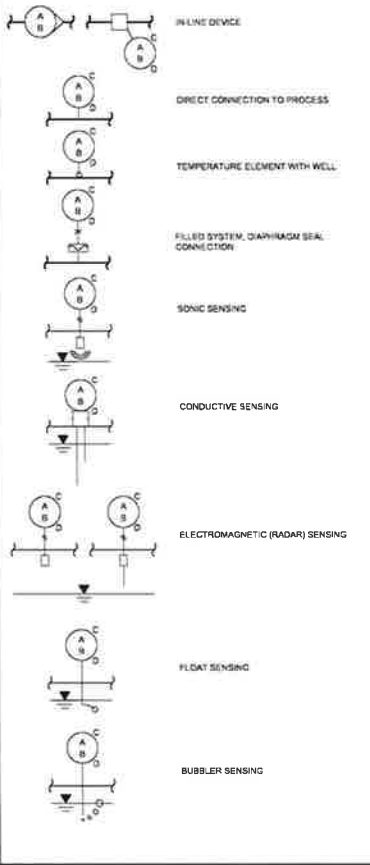

NOTES

- SEE THE GENERAL AND ELECTRICAL DISCIPLINE DRAWINGS FOR ADDITIONAL SYMBOLS AND ABBREVIATIONS.
- SEE THE GENERAL DISCIPLINE DRAWINGS FOR EQUIPMENT DESIGNATIONS AND PROCESS IDENTIFICATION CODES.
- THIS IS A GENERALIZED LEGEND SHEET. SEE ALSO ISA 5.1, SS 3 AND S7.3 FOR INSTRUMENT AIR QUALITY STANDARDS. REFER TO ISA RP7.7 WHERE LOOP NUMBERS EXCEED THE LENGTH AVAILABLE WITHIN A BUBBLE. THE LOWER HALF OF THE BUBBLE MAY APPEAR BROKEN TO ALLOW SPACE FOR THE LOOP NUMBER.
- SEE SPECIFICATION 1110 FOR COMPLETE DETAILS OF LOOP DRAWING AND INTERCONNECTION DRAWING SUBMITTAL REQUIREMENTS.
- POWER SUPPLIES FOR INSTRUMENT LOOPS OR SYSTEMS SHALL BE PROVIDED BY THE INSTRUMENTATION SUPPLIER TO MEET THE VOLTAGE AND CURRENT REQUIREMENTS OF THE COMPONENTS IN EACH LOOP OR SYSTEM.
- FIELD SWITCHES FOR ELECTRICAL MOTOR OPERATION SHALL BE SUPPLIED BY THE ELECTRICAL CONTRACTOR UNLESS THEY ARE PART OF A VENDOR PACKAGE.

60% SUBMITTAL

PRELIMINARY DESIGN PHASE
 NOT FOR CONSTRUCTION

THIS DOCUMENT IS AN INTERIM DOCUMENT AND NOT SUITABLE FOR CONSTRUCTION. AS AN INTERIM DOCUMENT, IT MAY CONTAIN DATA THAT IS POTENTIALLY INACCURATE OR INCOMPLETE AND IS NOT TO BE REPLIED UPON WITHOUT THE EXPRESS WRITTEN CONSENT OF THE PREPARED.

NO	REVISION	DATE	BY



DESIGNED	JLSAK
DRAWN	JLSAK
CHECKED	LDR

PORT OF PORT TOWNSEND
 PORT TOWNSEND, WASHINGTON
 BOAT HAVEN MARINA
 STORMWATER IMPROVEMENTS PHASE 2

INSTRUMENTATION LEGEND AND NOTES	
SCALE	NTS
JOB NO	2297020.01
DATE	JUNE 2024
SHEET	34 OF 34
I-001	



PN: Date: 6/13/2024 13:18 PM

User: STEPHAN KOWELUK

File: \\kenedy.com\kennedy\Documents\CAD\Projects\Port of Port Townsend\Port of Port Townsend\Marina Stormwater Improvements\Phase 2_2024\02\11\18\Design\19-08-24\app\plan\instrumentation\22970201-1-01.dwg

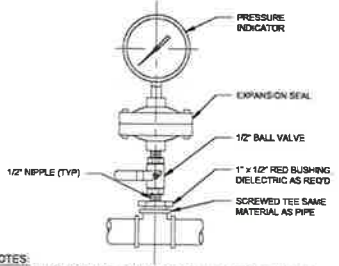

NOTES:
 1. FOR PRESSURE GAUGE IN STAINLESS STEEL LINES PROVIDE 316 L SS PIPING AND VALVES. FOR PLASTIC LINES PROVIDE PLASTIC VALVES AND PIPING FOR OTHER LINES PROVIDE BRASS OR BRONZE. SEE DIVISION 15.

PRESSURE GAUGE
 WITH DIAPHRAGM SEAL

I-0206
 SCALE: NTS
 REV 00

60% SUBMITTAL

PRELIMINARY DESIGN PHASE
 NOT FOR CONSTRUCTION

THIS DOCUMENT IS AN INTERIM DOCUMENT AND NOT SUITABLE FOR CONSTRUCTION. AS AN INTERIM DOCUMENT, IT MAY CONTAIN DATA THAT IS POTENTIALLY INACCURATE OR INCOMPLETE AND IS NOT TO BE RELIED UPON WITHOUT THE EXPRESS WRITTEN CONSENT OF THE PREPARER.

NO	REVISION	DATE	BY

SCALES
 0 1"
 0 25mm
 IF THIS BAR IS NOT DIMENSION SHOWN, ADJUST SCALES ACCORDINGLY

DESIGNED	J/SAK
DRAWN	J/SAK
CHECKED	LGR

PORT OF PORT TOWNSEND
 PORT TOWNSEND, WASHINGTON
 BOAT HAVEN MARINA
 STORMWATER IMPROVEMENTS PHASE 2



INSTRUMENTATION DETAILS

SCALE	NTS
JOB NO.	22970201
DATE	JUNE 2024
SHEET	M DP

Plot Date: 01/20/24 2:11 PM
 User: SAMANTHA KARPA
 File Path: \\pdc\pdc\projects\2024\2297020\110\110.dwg
 Project: Port of Townsend Stormwater Improvements Phase 2
 Sheet: 39 of 41

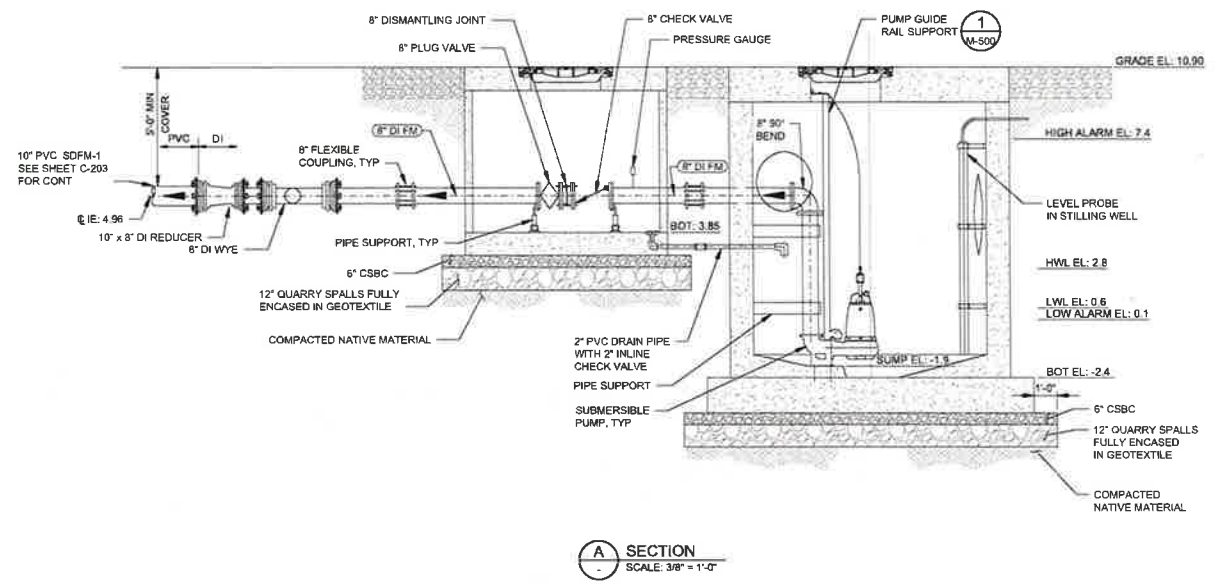
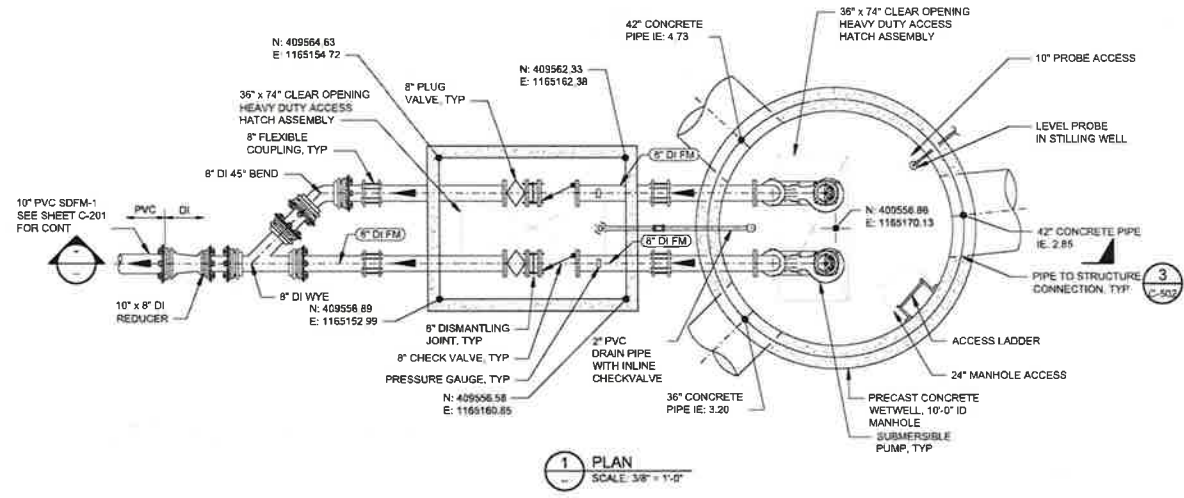

60% SUBMITTAL

PRELIMINARY DESIGN PHASE
NOT FOR CONSTRUCTION

THIS DOCUMENT IS AN INTERIM DOCUMENT AND NOT SUITABLE FOR CONSTRUCTION. AS AN INTERIM DOCUMENT, IT MAY CONTAIN DATA THAT IS POTENTIALLY INACCURATE OR INCOMPLETE AND IS NOT TO BE RELIED UPON WITHOUT THE EXPRESS WRITTEN CONSENT OF THE PREPARER.

NO.	REVISION	DATE	BY

SCALES

0" = 1"
0" = 25mm
IF THIS BAR IS NOT DIMENSION SHOWN, ADJUST SCALES ACCORDINGLY.

THIS PRELIMINARY DOCUMENT IS NOT FOR CONSTRUCTION. IT IS RELEASED UNDER THE AUTHORITY OF:
SAMANTHA KARPA
2/12/24 4:58
JUNE 2024

DESIGNED	SNK
DRAWN	CEC
CHECKED	SNK

PORT OF PORT TOWNSEND
PORT TOWNSEND, WASHINGTON
BOAT HAVEN MARINA
STORMWATER IMPROVEMENTS PHASE 2



STORMWATER LIFT STATION EAST
PLAN AND SECTION

SCALE	3/8" = 1'-0"
CS NO	2297020 01
DATE	JUNE 2024
SHEET	39 OF 41
	M-101

SINGLE LINE DIAGRAM SYMBOLS

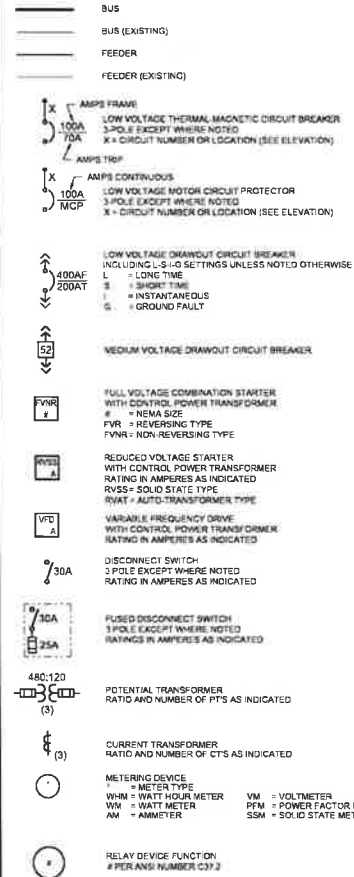

15/25	AUTO SYNCHRONIZER RELAY	50/51N	INST/TIME RESIDUALLY CONNECTED GND OVERCURRENT
25	SYNCHRONISM CHECK RELAY	51G	50M FAULT RELAY
27	UNDERVOLTAGE RELAY	52	POWER CIRCUIT BREAKER
27/55	UNDEROVERVOLTAGE RELAY	55	POWER FACTOR TRIP RELAY
32	DIRECTIONAL POWER RELAY	60	VOLTAGE BALANCE
37	UNDERCURRENT RELAY	82	TIME DELAY
38	HIGH TEMP (BEARING)	85	GOVERNOR (LOAD SHARING/SOFT LANDING CONTROL)
39	VIBRATION RELAY	86	TIME BETWEEN STARTS RELAY
40	LOSS OF FIELD/UNDER EXCITATION RELAY	87	DIRECTIONAL REVERSE VARIWIP RELAY
41	FELD CONTACTOR	71L	LOW OIL LEVEL RELAY
43	SELECTOR SWITCH	81/OU	OVERCURRENT FREQUENCY RELAY
43	CURRENT BALANCE RELAY	83	CONTROL POWER TRANSFORMER
47	PHASE SEQUENCE FAILURE RELAY	85	UTILITY LOCKOUT RELAY
48	GROUND FAULT INCOMPLETE SEQUENCE RELAY	87TL	TRANSFORMER DIFFERENTIAL RELAY
49	HIGH TEMP (OIL OR STATOR)	87M	MOTOR DIFFERENTIAL RELAY
55/51	INST/TIME OVERCURRENT RELAY	90	VARIWIP AND CROSS CURRENT COMPENSATION CONTROLLER
55/51G	INST/TIME DIRECTLY CONNECTED GND OVERCURRENT RELAY		

CONTROL SCHEMATIC SYMBOLS

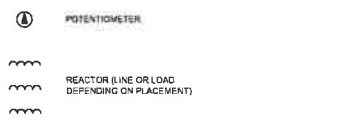
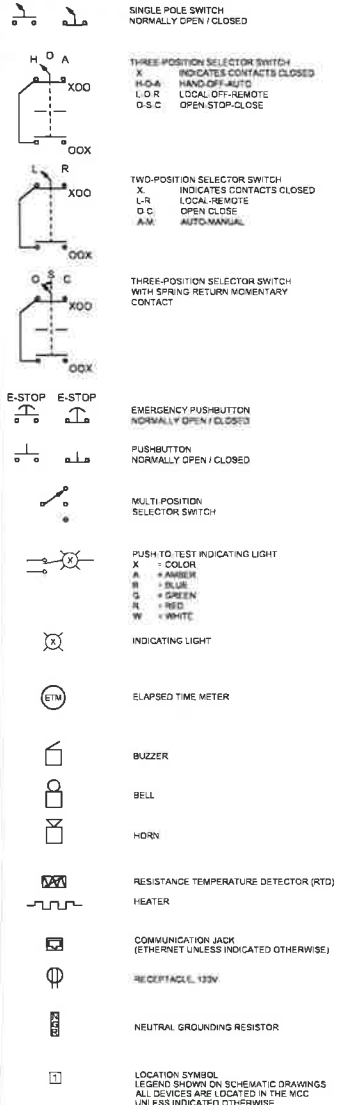
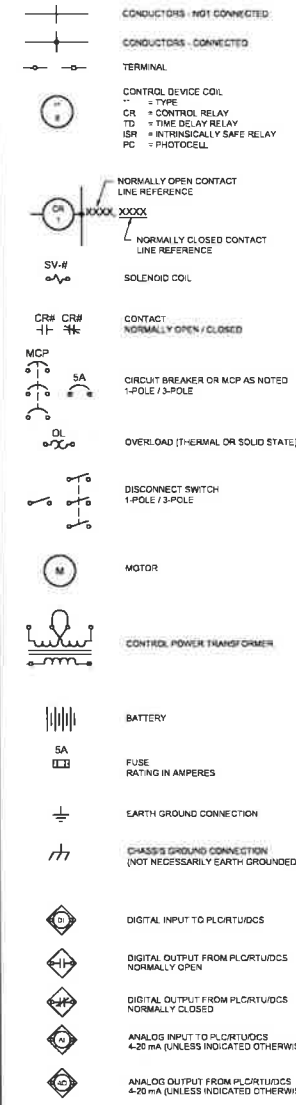

CLOSE ON		SENSED VARIABLE	
RISING	FALLING		
FS	FS	FLOW	
LS	LS	LEVEL	
PS	PS	PRESSURE	
TS	TS	TEMPERATURE	
LIMIT SWITCHES			
ZS	ZS	NORMALLY OPEN, CLOSE ON REACHING LIMIT	
ZS	ZS	NORMALLY CLOSED, OPEN ON REACHING LIMIT	
TORQUE SWITCH			
		NORMALLY CLOSED, OPEN ON INCREASING TORQUE	
TIMED CONTACTS			
SYMBOL	NORMAL	OPEN TO CLOSED	CLOSED TO OPEN
TR	OPEN	DELAYED	INSTANTANEOUS
TR	CLOSED	INSTANTANEOUS	DELAYED
TR	OPEN	INSTANTANEOUS	DELAYED
TR	CLOSED	DELAYED	INSTANTANEOUS

60% SUBMITTAL

PRELIMINARY DESIGN PHASE
 NOT FOR CONSTRUCTION
 THIS DOCUMENT IS AN INTERIM DOCUMENT AND NOT SUITABLE FOR CONSTRUCTION. AS AN INTERIM DOCUMENT, IT MAY CONTAIN DATA THAT IS POTENTIALLY INACCURATE OR INCOMPLETE AND IS NOT TO BE RELIED UPON WITHOUT THE EXPRESS WRITTEN CONSENT OF THE PREPARED.

NO	REVISION	DATE	BY



DESIGNED	PORT OF PORT TOWNSEND PORT TOWNSEND, WASHINGTON
DRAWN	BOAT HAVEN MARINA STORMWATER IMPROVEMENTS PHASE 2
CHECKED	Kennedy Jenks

ELECTRICAL LEGEND - I	
SCALE	NTS
JOB NO.	2287020 01
DATE	JUNE 2024
SHEET	01
E-002	

Proj Date: 6/13/2024 3:57 PM

User: TMMITTY KELLY

All rights reserved by Kennedy Jenks and its affiliates. All other trademarks and registered trademarks are the property of their respective owners. No part of this document may be reproduced without the express written consent of the preparer.

PLAN SYMBOLS

CONDUIT AND RACEWAYS

- CONDUIT - MULTIPLE IN DUCT BANK
- MULTIPLE CONDUIT RUN
- CONDUIT - ENCASED OR UNDERGROUND
- CONDUIT - EXPOSED OR CONCEALED
- CALLOUT INDICATING CONDUIT PER SCHEDULE (P-135)
- HOME RUN TO PANEL BOARD OR AS INDICATED (3# - CONDUIT, 2 #2, 1 #12 GND UNLESS INDICATED OTHERWISE)
- FLEXIBLE CONDUIT
- CONDUIT RUN CONTINUES ON SAME SHEET OR AS NOTED
- CONDUIT - CAPPED OR SEALED
- OPEN CIRCLE DENOTES UPWARD CONDUIT RISER
- SEMI CIRCLE DENOTES DOWNWARD CONDUIT RISER
- JUNCTION BOX
- UNDERGROUND RACEWAY MANHOLE DIMENSIONS AS NOTED (HH#)
- UNDERGROUND RACEWAY MANHOLE DIMENSIONS AS NOTED (MM#)

EQUIPMENT

- MOTOR (M)
- PANEL OR CABINET - AS LABELED (SWBD, SWGR, MCC, LP, PNLBD, P.C, ETC)

GROUNDING

- BARE COPPER GROUND TO GROUND WIRE IN SLAB OR UNDERGROUND GROUND GRID, SIZE AS NOTED
- GROUND CONNECTION - BOLTED
- GROUND CONNECTION - EXOTHERMICALLY WELDED
- GROUND ROD - IN WELL WITH BOX
- GROUND ROD - BURIED

FIRE PROTECTION

- FIRE ALARM PULL STATION
- FIRE ALARM STROBE
- FIRE ALARM HORN
- FIRE ALARM HORN/STROBE
- SMOKE DETECTOR (SD)
- HEAT DETECTOR (HD)

LIGHTING

- LUMINAIRE CALLOUT (A) = LUMINAIRE TYPE, # = APPROXIMATE MOUNTING HEIGHT AFF, C.L.G. = CEILING MOUNT (SEE LUMINAIRE SCHEDULE FOR MORE DETAILS)
- LUMINAIRE - STRIP OR TROFFER TYPE (SWITCHED/UNSWITCHED) (X) = LIGHTING PANEL DESIGNATION, # = CIRCUIT NUMBER, A = SWITCH DESIGNATION
- WALL MOUNTED LUMINAIRE (SWITCHED/UNSWITCHED)
- PENDANT/CEILING MOUNTED LUMINAIRE (SWITCHED/UNSWITCHED)
- POLE, BRACKET, ARM, AND MOUNTED LUMINAIRE
- RECESSED CAN LUMINAIRE (SWITCHED/UNSWITCHED)
- EMERGENCY LUMINAIRE WITH SELF CONTAINED BATTERY
- WALL/CEILING MOUNTED EXIT LIGHT (DIRECTIONAL ARROW WHERE INDICATED, SHADED AREA INDICATES ILLUMINATED FACE)
- LIGHT SWITCH (X) = LIGHTING PANEL DESIGNATION, # = CIRCUIT NUMBER, A = SWITCH DESIGNATION, T = SWITCH TYPE, 1 = 1 WAY, 2 = 2 WAY, 3 = 3 WAY, 4 = 4 WAY, D = DIMMER
- MOTION SENSOR
- OCCUPANCY SENSOR
- PHOTOCELL
- TIME CLOCK

RECEPTACLES

- DUPLEX RECEPTACLE, 120V, WALL MOUNT NEMA 5-20R CONFIGURATION (X) = LIGHTING PANEL DESIGNATION, # = CIRCUIT NUMBER, A = AMPERAGE, WP = WEATHERPROOF, XP = EXPLOSION PROOF, GFCI = GROUND FAULT CIRCUIT INTERRUPTER
- DUPLEX RECEPTACLE, 120V, FLOOR MOUNT NEMA 5-20R CONFIGURATION (X) = LIGHTING PANEL DESIGNATION, # = CIRCUIT NUMBER, A = AMPERAGE
- SINGLE SPECIAL RECEPTACLE, 208V OR 240V, 1-PHASE (X) = PANEL DESIGNATION, # = CIRCUIT NUMBER, A = AMPERAGE
- SINGLE SPECIAL WELDING RECEPTACLE, 208V OR 240V, 3-PHASE (X) = PANEL DESIGNATION, # = CIRCUIT NUMBER, A = AMPERAGE
- SINGLE SPECIAL RECEPTACLE, 480V, 3-PHASE (X) = PANEL DESIGNATION, # = CIRCUIT NUMBER, A = AMPERAGE

SECURITY AND COMMUNICATION

- ANTENNA
- VIDEO CAMERA (T) = TYPE, F = FIXED, PTZ = PAN/TILT/ZOOM, 360 = 360 DEGREE FIXED
- SECURITY ACCESS DEVICE (C) = TYPE, CR = CARD READER, KS = KEY SWITCH, KP = KEYPAD, RF = RADIO FREQUENCY ID
- TELEPHONE OUTLET (WALL MOUNTED/FLOOR MOUNTED)
- DATA OUTLET (WALL MOUNTED/FLOOR MOUNTED)
- TELEPHONE/DATA COMBINATION OUTLET (WALL MOUNTED/FLOOR MOUNTED)
- TELEVISION ANTENNA/CABLE OUTLET

MISCELLANEOUS

- DISCONNECT SAFETY SWITCH
- INSTRUMENT
- SWITCH - SPECIAL PURPOSE (X) = LIGHTING PANEL DESIGNATION, # = CIRCUIT NUMBER, T = SWITCH TYPE, M = MOTOR RATED, K = KEY OPERATED, T = TIMER
- THERMOSTAT
- CLASS I, DIVISION 1 HAZARDOUS AREA BOUNDARY (LABEL APPEARS IN CLASSIFIED AREA) (CID1)
- CLASS I, DIVISION 2 HAZARDOUS AREA BOUNDARY (LABEL APPEARS IN CLASSIFIED AREA) (CID2)

60% SUBMITTAL

PRELIMINARY DESIGN PHASE NOT FOR CONSTRUCTION

THIS DOCUMENT IS AN INTERIM DOCUMENT AND NOT SUITABLE FOR CONSTRUCTION. AS AN INTERIM DOCUMENT, IT MAY CONTAIN DATA THAT IS POTENTIALLY INACCURATE OR INCOMPLETE AND IS NOT TO BE RELIED UPON WITHOUT THE EXPRESS WRITTEN CONSENT OF THE PREPARER.

NO	REVISION	DATE	BY

SCALES
 0" = 1'
 0" = 25mm
 IF THIS BAR IS NOT DIMENSION SHOWN, ADJUST SCALES ACCORDINGLY.

DESIGNED
DRAWN
CHECKED

PORT OF PORT TOWNSEND
 PORT TOWNSEND, WASHINGTON
BOAT HAVEN MARINA
 STORMWATER IMPROVEMENTS PHASE 2



ELECTRICAL LEGEND - II

SCALE
JOB NO. 229720 01
DATE JUNE 2024
SHEET 01

Plot Date: 01/20/24 3:27 PM

User: TMD\TJ\JELLY

File: \\c:\projects\port_townsend\stormwater\stormwater\phase2\22910201.dwg Design: 11/10/2023 10:00:00 AM

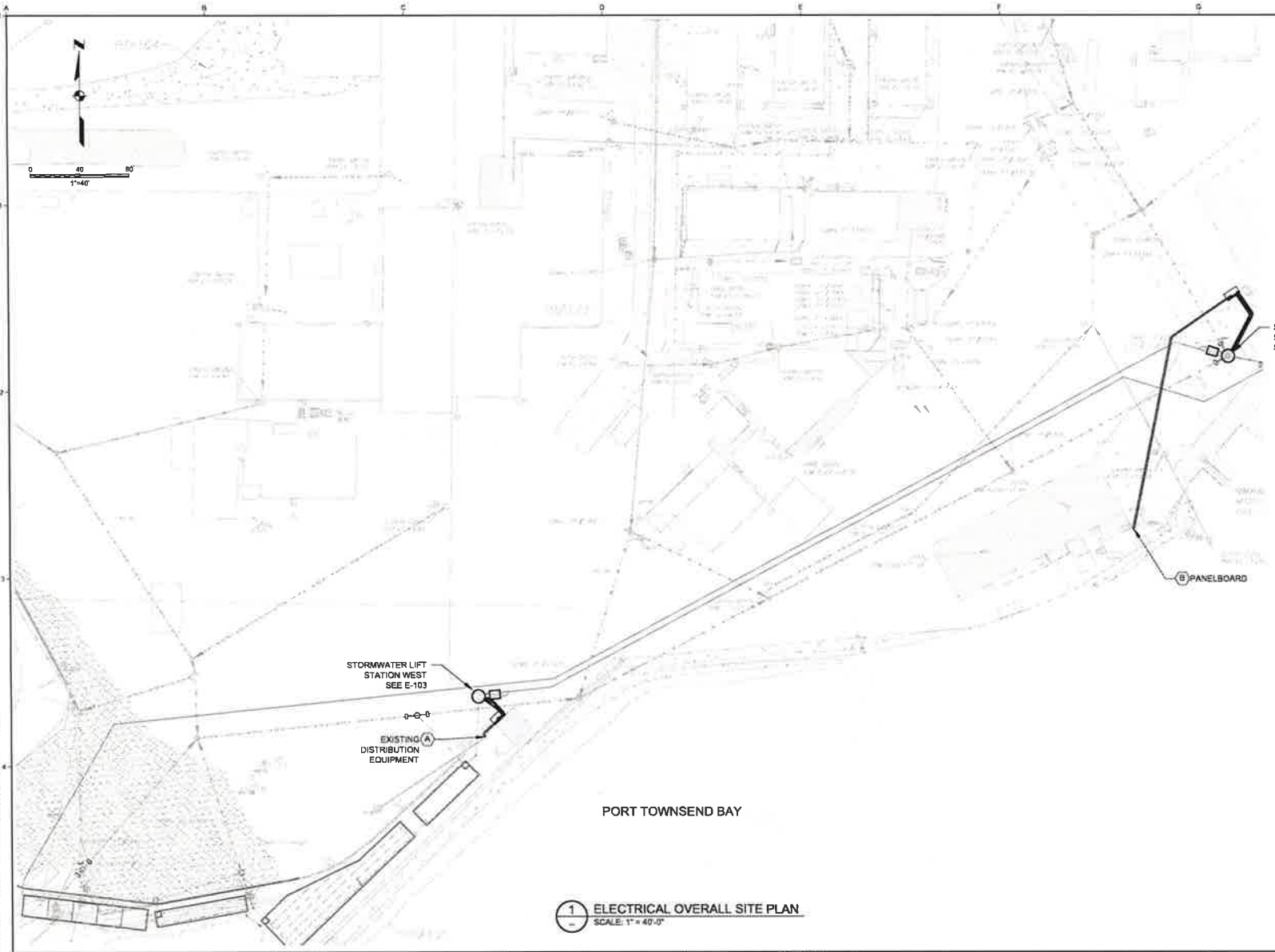

- GENERAL SHEET NOTES**
- CONTRACTOR SHALL FIELD VERIFY ALL EXISTING SITE CONDITIONS PRIOR TO COMMENCING ANY WORK.
- SHEET KEYNOTES**
- APPROXIMATE LOCATION OF EXISTING METER 10771105 AND ASSOCIATED 208/120VAC, 3ø DISTRIBUTION EQUIPMENT
 - APPROXIMATE LOCATION OF EXISTING 480/277VAC, 3ø, 4W 5øD NF, 400A, 18KA RATED PANELBOARD. FURNISH AND INSTALL NEW FEEDER CIRCUIT BREAKER AS SHOWN FOR STORMWATER LIFT STATION EAST. REFER TO ONE-LINE DIAGRAM AND PANELBOARD SCHEDULES FOR ADDITIONAL INFORMATION.

1 ELECTRICAL OVERALL SITE PLAN
SCALE: 1" = 40'-0"

60% SUBMITTAL

PRELIMINARY DESIGN PHASE
NOT FOR CONSTRUCTION

THIS DOCUMENT IS AN INTERIM DOCUMENT AND NOT SUITABLE FOR CONSTRUCTION. AS AN INTERIM DOCUMENT, IT MAY CONTAIN DATA THAT IS POTENTIALLY INACCURATE OR INCOMPLETE AND IS NOT TO BE RELIED UPON WITHOUT THE EXPRESS WRITTEN CONSENT OF THE PREPARER.

NO.	REVISION	DATE	BY

SCALES
 0" = 1"
 0" = 25mm
 IF THIS BAR IS NOT DIMENSION SHOWN, ADJUST SCALES ACCORDINGLY.

DESIGNED	TK
DRAWN	TK
CHECKED	JD

PORT OF PORT TOWNSEND
 PORT TOWNSEND, WASHINGTON
BOAT HAVEN MARINA
STORMWATER IMPROVEMENTS PHASE 2
 Kennedy Jenks

ELECTRICAL
OVERALL SITE PLAN

SCALE	1" = 40'
JOB NO.	22910201-01
DATE	JUNE 2024
SHEET OF	E-100

Pkl Date: 6/17/2024 3:07 PM

User: TIMOTHY KELLY

2

3

4

5

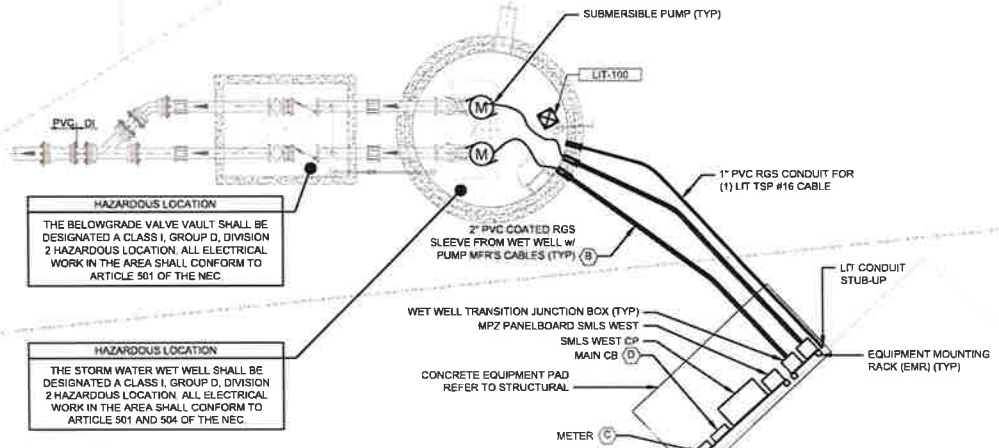
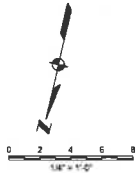

GENERAL SHEET NOTES

1. PROVIDE SITE RESTORATION FOR ANY DISTURBED SURFACES IMPACTED BY CONDUITS, DUCTS, SLEEVES OR ANY ELECTRICAL EQUIPMENT.
2. COORDINATE UNDERGROUND ELECTRICAL SITE WORK WITH ALL EXISTING UTILITIES.

SHEET KEYNOTES

- A. ELECTRICAL PENETRATIONS THROUGH PRECAST CONCRETE WET WELL SHALL BE VIA MODULAR PIPE SEALING SYSTEM (LINK-SEAL OR EQUAL) (TYP)
- B. COORDINATE PUMP SUBCAB TYPE POWER & MULTICORE CONTROL TYPE SO CABLE LENGTH WITH PUMP MFR AND FIELD CONDITIONS. INSTALLATION OF PUMPS AND CONNECTED PUMP CABLES SHALL FACILITATE EASY REMOVAL OF PUMPS FOR MAINTENANCE PURPOSES.
- C. FURNISH AND INSTALL SELF-CONTAINED METER SOCKET FOR NEW SERVICE TO STORMWATER LIFT STATION WEST IN ACCORDANCE WITH JEFFERSON COUNTY PUD REQUIREMENTS.
- D. FURNISH AND INSTALL NEMA 4X SS ENCLOSED CIRCUIT BREAKER SUITABLE FOR USE AS SERVICE EQUIPMENT WITH ISOLATED NEUTRAL BUS AND SERVICE GROUND KIT - BONDING JUMPER.
- E. APPROXIMATE LOCATION OF EXISTING 208Y/120VAC, 3Ø DISTRIBUTION EQUIPMENT.

1 ELECTRICAL STORMWATER LIFT STATION WEST PLAN
SCALE: 1/4" = 1'-0"

60% SUBMITTAL

PRELIMINARY DESIGN PHASE
NOT FOR CONSTRUCTION

THIS DOCUMENT IS AN INTERIM DOCUMENT AND NOT SUITABLE FOR CONSTRUCTION. AS AN INTERIM DOCUMENT, IT MAY CONTAIN DATA THAT IS POTENTIALLY INACCURATE OR INCOMPLETE AND IS NOT TO BE RELED UPON WITHOUT THE EXPRESS WRITTEN CONSENT OF THE PREPARER.

NO.	REVISION	DATE	BY

SCALES
0" = 1"
0" = 25mm
IF THIS BAR IS NOT DIMENSION SHOWN, ADJUST SCALES ACCORDINGLY.

DESIGNED	TK
DRAWN	TK
CHECKED	ZD

PORT OF PORT TOWNSEND
PORT TOWNSEND, WASHINGTON
BOAT HAVEN MARINA
STORMWATER IMPROVEMENTS PHASE 2



ELECTRICAL
STORMWATER LIFT STATION WEST PLAN

SCALE	1/4" = 1'-0"
JOB NO.	228P200.01
DATE	JUNE 2024
SHEET	OF -
E-102	

A B C D E F G H

Per Date: 6/11/2024 3:58 PM

DATE: TIMOTHY KELLY

C:\Users\tdkelly\OneDrive\Documents\Port of Townsend\Boat Haven Stormwater Improvements Phase 2\2297020\01\01\Drawings\Electrical\E-201.dwg

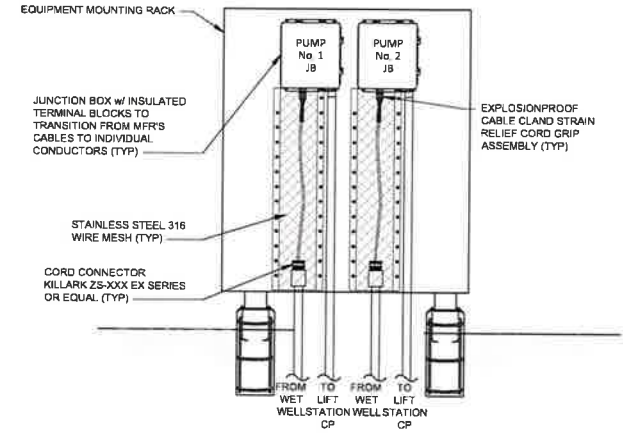

1 CABLE TRANSITION FROM WET WELL DETAIL
 (E-201) SCALE: NTS

60% SUBMITTAL PRELIMINARY DESIGN PHASE NOT FOR CONSTRUCTION THIS DOCUMENT IS AN INTERIM DOCUMENT AND NOT SUITABLE FOR CONSTRUCTION. AS AN INTERIM DOCUMENT, IT MAY CONTAIN DATA THAT IS POTENTIALLY INACCURATE OR INCOMPLETE AND IS NOT TO BE RELIED UPON WITHOUT THE EXPRESS WRITTEN CONSENT OF THE PREPARER.	NO	REVISION	DATE	BY	SCALES 0" = 1' 0" = 25mm IF THIS BAR IS NOT DIMENSION SHOWN, ADJUST SCALES ACCORDINGLY.	DESIGNED TK	PORT OF PORT TOWNSEND PORT TOWNSEND, WASHINGTON BOAT HAVEN MARINA STORMWATER IMPROVEMENTS PHASE 2 Kennedy Jenks	ELECTRICAL DETAILS	SCALE: NTS
						DRAWN TK			JOB NO: 2297020 01
					CHECKED ZD	DATE: JUNE 2024			
								SHEET: 01	E-201

Plot Date: 6/15/2024 3:15 PM
 User: TIMOTHY KELLY
 s:\projects\61600\61600.dwg

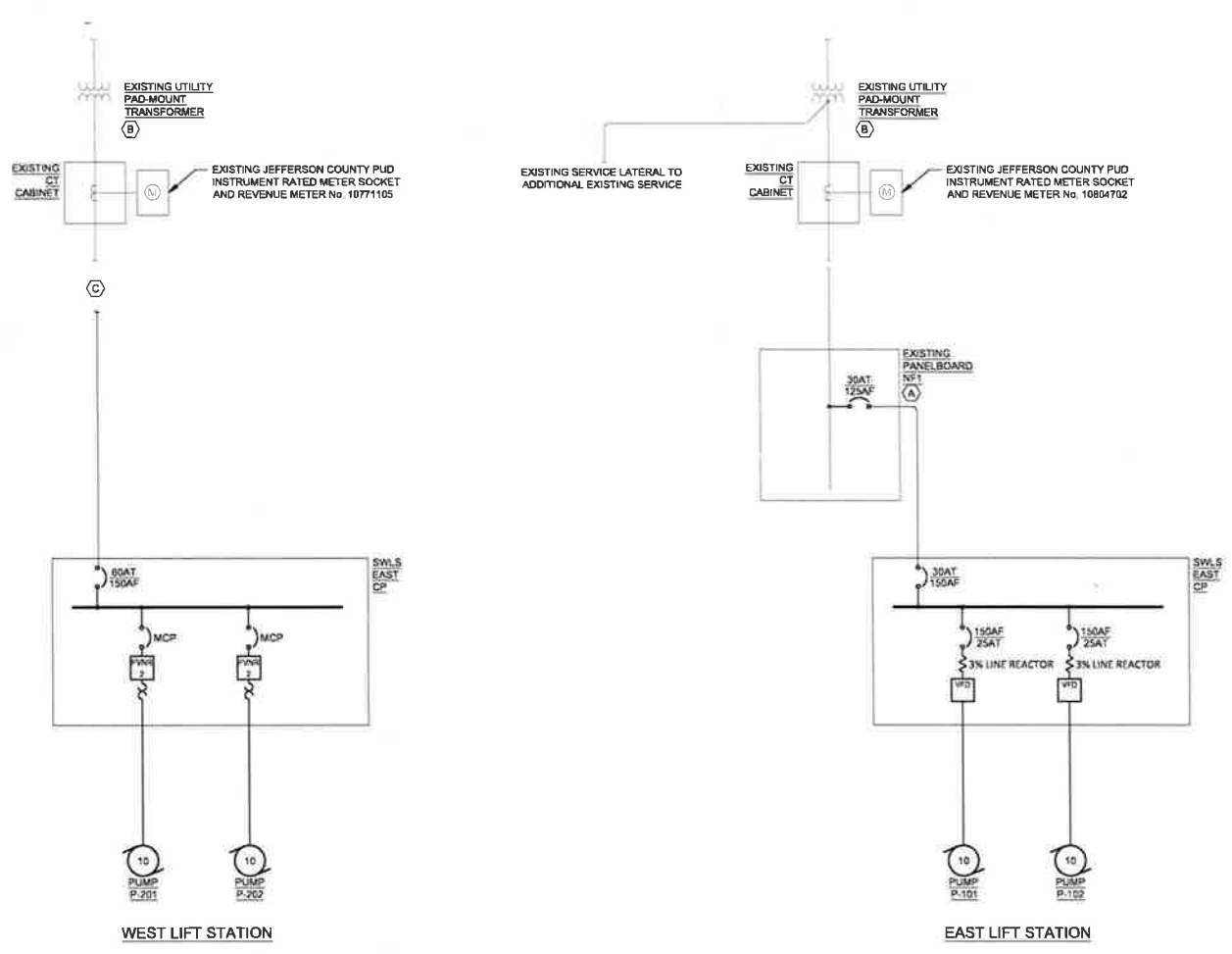

- GENERAL SHEET NOTES**
- CONTRACTOR SHALL VERIFY ALL EXISTING FIELD CONDITIONS PRIOR TO COMMENCING WORK.
 - AVAILABLE FAULT CURRENT PENDING, AIC AND SCRR RATINGS SHOWN ARE MINIMUMS.
 - ALL SHUTDOWNS REQUIRED FOR TIE IN TO EXISTING DISTRIBUTION SYSTEMS SHALL BE COORDINATED WITH THE PORT TWO WEEKS IN ADVANCE.
- SHEET KEYNOTES**
- EXISTING 480/277VAC, 3ø, 4W S-D NF, 400A, 18KA RATED PANELBOARD - FURNISH AND INSTALL NEW FEEDER CIRCUIT BREAKER AS SHOWN FOR STORMWATER LIFT STATION EAST. REFER TO PANELBOARD SCHEDULES FOR ADDITIONAL INFORMATION.
 - EXISTING PAD-MOUNT UTILITY TRANSFORMER: JEFFERSON COUNTY PUD TRANSFORMER # 40430 640915 152419 w/ 208Y/120VAC, 3ø SECONDARY.
 - EXISTING 208/120VAC, 3ø DISTRIBUTION EQUIPMENT PENDING AND SLATED TO BE UTILIZED TO SUPPLY NEW FEEDER TO SWLS EAST CP AS SHOWN.

60% SUBMITTAL PRELIMINARY DESIGN PHASE <small>NOT FOR CONSTRUCTION</small> <small>THIS DOCUMENT IS AN INTERIM DOCUMENT AND NOT SUITABLE FOR CONSTRUCTION. AS AN INTERIM DOCUMENT, IT MAY CONTAIN DATA THAT IS POTENTIALLY INACCURATE OR INCOMPLETE AND IS NOT TO BE RELIED UPON WITHOUT THE EXPRESS WRITTEN CONSENT OF THE PREPARED.</small>	NO	REVISION	DATE	BY	SCALES 0" = 1' 0 = 25mm <small>IF THIS BAR IS NOT DIMENSION SHOWN, ADJUST SCALES ACCORDINGLY.</small>	DESIGNED: TK DRAWN: TK CHECKED: ZD	PORT OF PORT TOWNSEND PORT TOWNSEND, WASHINGTON BOAT HAVEN MARINA STORMWATER IMPROVEMENTS PHASE 2 Kennedy Jenks	ELECTRICAL SINGLE LINE DIAGRAMS	SCALE: JOB NO: 2287300.01 DATE: JUNE 2024 SHEET: CP - E-301

